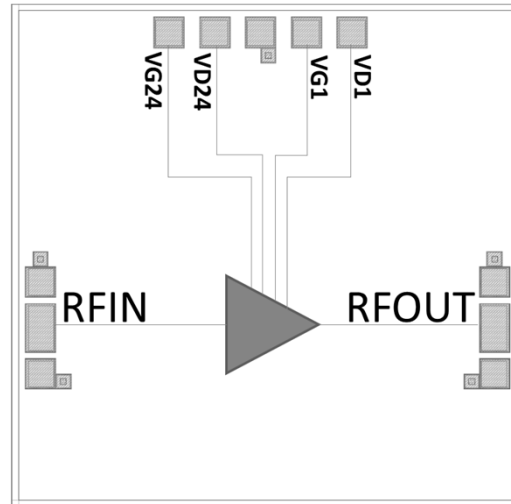

Features

- Frequency: 17GHz - 44GHz
- Small Signal Gain: 22 dB
- Gain Flatness: $\leq \pm 2$ dB
- Noise Figure < 8dB, 27GHz – 45GHz
- P1dB = 22 dBm at 32 GHz
- Power Supply: +6V/156mA
- Input/Output: 50 Ω
- Die Size: 1.63 x 1.6 x 0.07 mm

Functional Block Diagram

Typical Applications

- Test Instrumentation
- Microwave Radio & VSAT
- Military & Space
- Telecom Infrastructure
- Fiber Optics

Electrical Specifications

TA = +25°C, VD1, VD23 = +6V, VG1, VG24 = -0.3V, ID1 = 72mA, ID24 = 84mA

Parameters	Min.	Typ.	Max.	Min.	Typ.	Max.	Units
Frequency	17-38		38-44				GHz
Small Signal Gain		21			22		dB
Gain Flatness		± 1			± 1		dB
Noise Figure		< 14			< 7		dB
Output 1dB Compression (P1dB)		> 20			> 18		dBm
Saturated Output Power (Psat)		> 22			> 19		dBm
Input Return Loss		> 10			> 6		dB
Output Return Loss		> 5			> 5		dB

* Adjust VG1, VG23 slightly to obtain device currents ID1 = 72mA and ID24 = 84 mA.



Outline Drawing: All Dimensions in μm

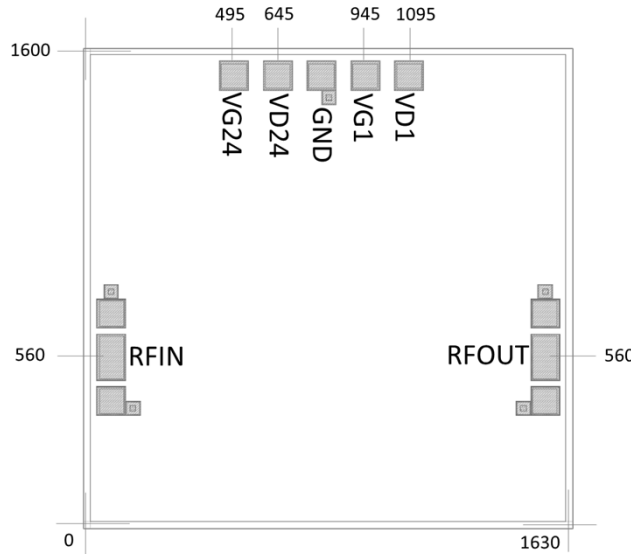

Pad Description

No	Function	Description
1	RF IN	Signal input terminal, connected to 50Ω circuit
2	RF OUT	Signal output terminal, connected to 50Ω circuit
3	VG1	Amplifier 1 st gate bias; connect to external 1000pF and 0.01uF bypass capacitors.
4	VG24	Amplifier 2 nd gate bias; connect to external 1000pF and 0.01uF bypass capacitors.
5	VD1	Amplifier 1 st drain bias; connect to external 1000pF and 0.01uF bypass capacitors.
6	VD24	Amplifier 2 nd drain bias; connect to external 1000pF and 0.01uF bypass capacitors
7	GND1, GND2	Ground pads.



Measurement Plots: S-parameters

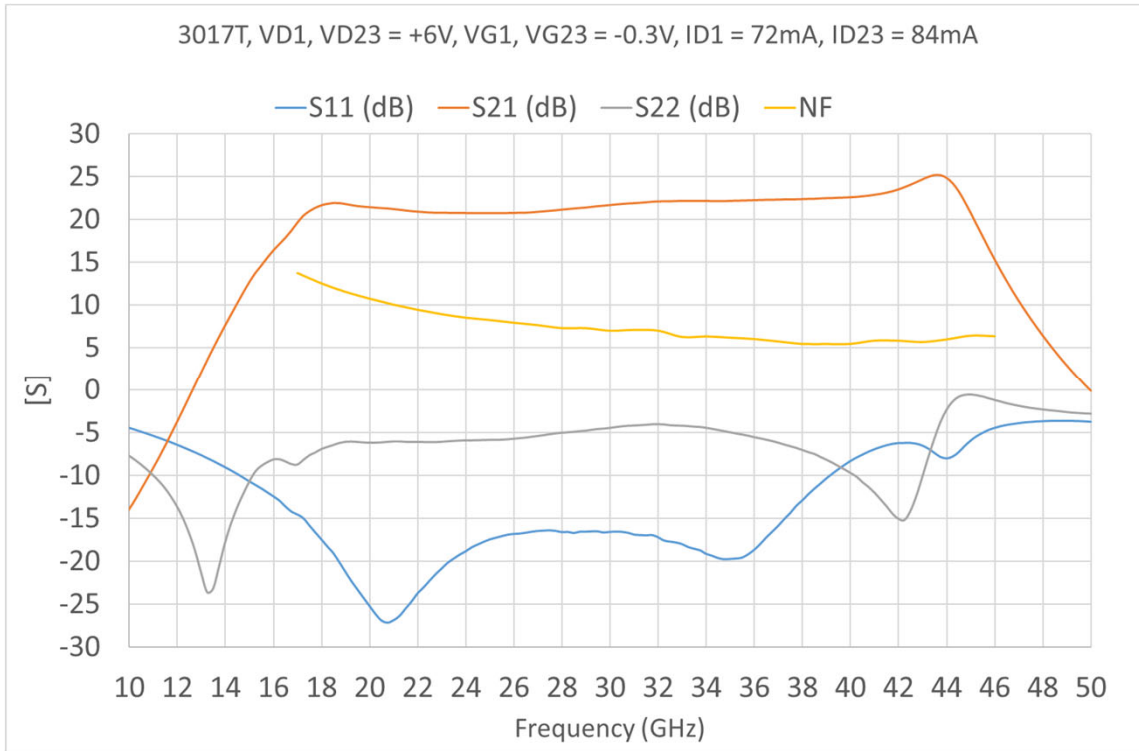

Measurement Plots: P1dB and Psat

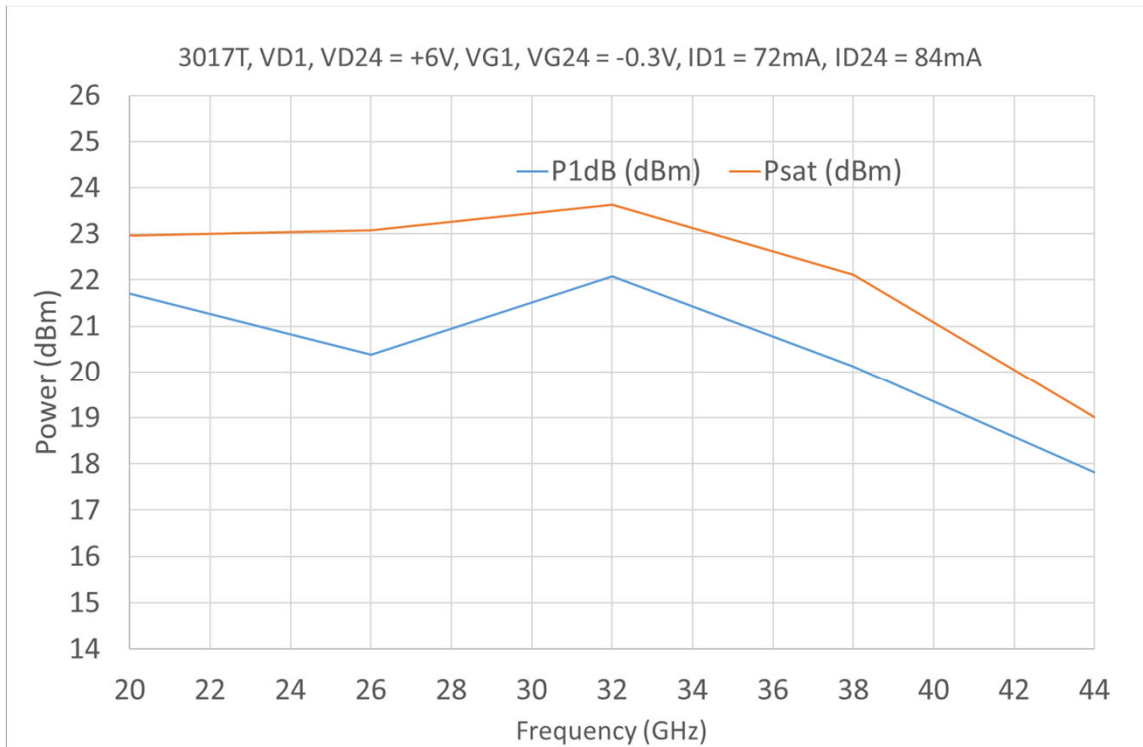



Assembly Drawing

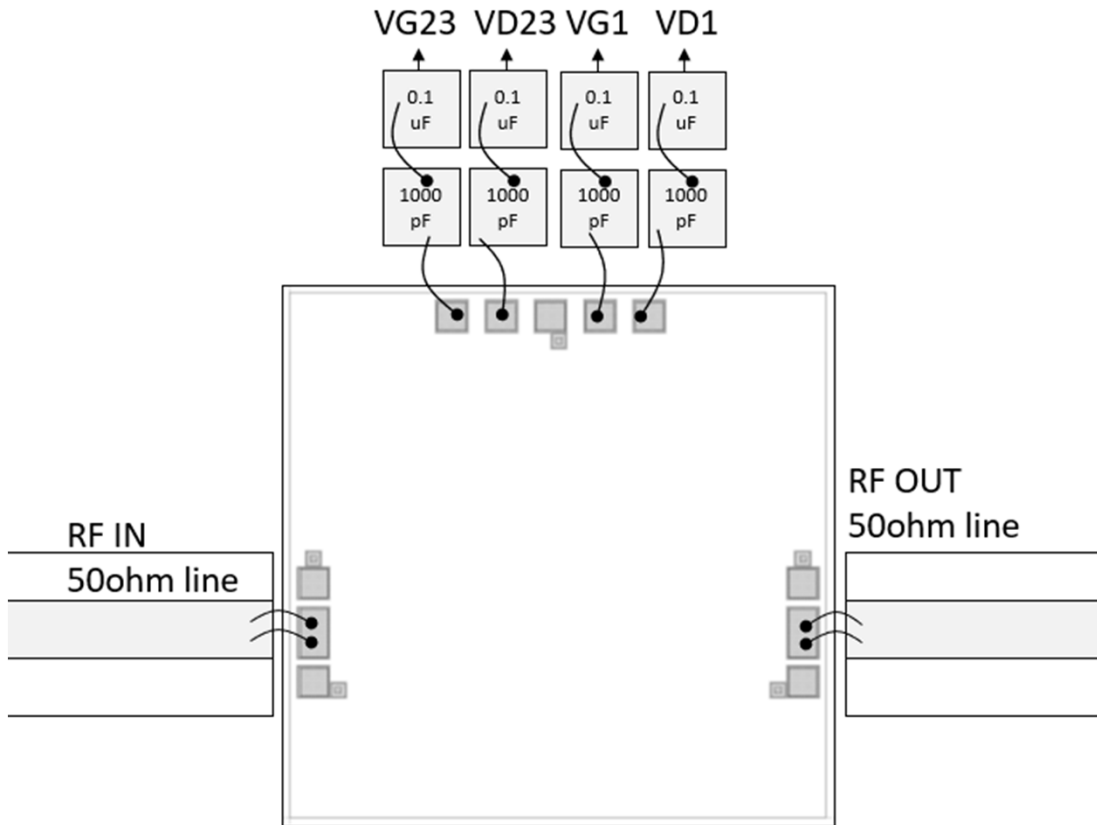

Notes:

1. Die thickness: 70um
2. DC bond pad is 100 x 100 μm^2
3. RF IN/OUT bond pad is 100 x 160 μm^2
4. Bond pad metalization: Gold
5. Backside metalization: Gold
6. Backside of the die (GND)