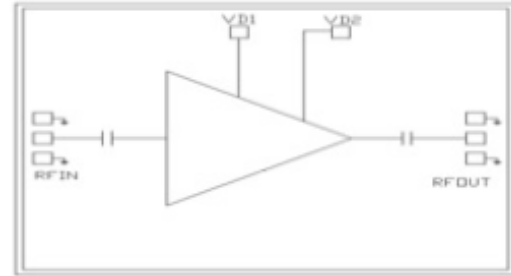

Features

- Frequency: 2.6-4.2GHz
- Small Signal Gain: 28.5dB
- P1dB: 23dBm
- Psat: 24.5dBm
- Power Supply: 5V@155mA
- Input/Output: 50Ω
- Die Size: 2.62 x 1.52 x 0.1 mm

Functional Block Diagram

Typical Applications

- Test Instrumentation
- Microwave Radio & VSAT
- Military & Space
- Telecom Infrastructure
- Fiber Optics

Electrical Specifications

TA = +25°C, Vd = +5V

Parameters	Min.	Typ.	Max.	Units
Frequency	2.6-4.2			GHz
Small Signal Gain	28	28.5	129	dB
Gain Flatness		±0.5		dB
P1dB	22.5	23	24	dBm
Psat	23.5	24.5		dBm
Input Return Loss	8	16		dB
Output Return Loss	7.5	13		dB
Quiescent Current		155		mA



Gain vs. Frequency

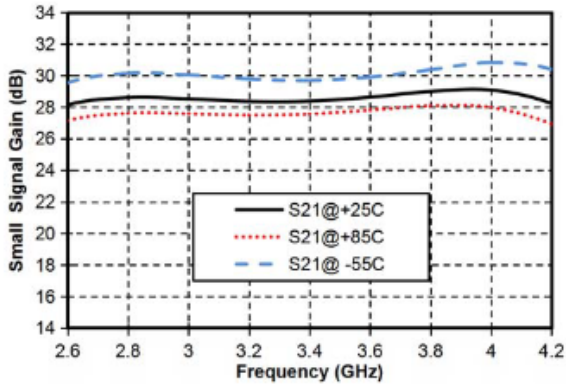

Reverse Isolation vs. Frequency

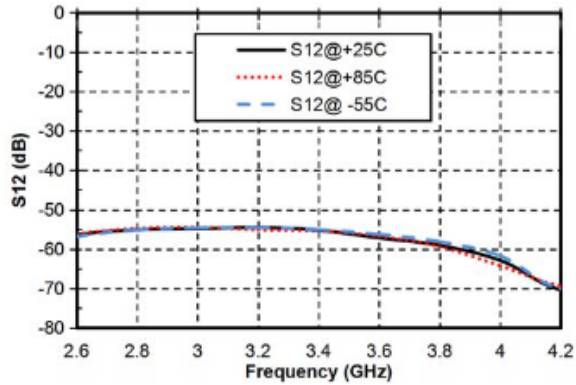

Input Return Loss vs. Frequency

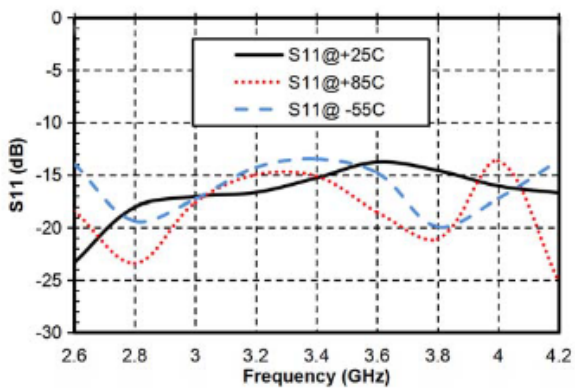

Output Return Loss vs. Frequency

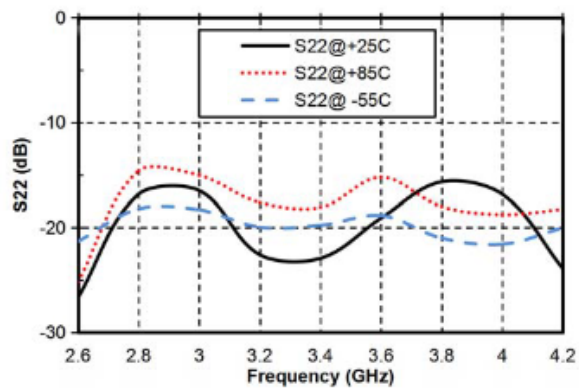

P-1dB vs. Frequency

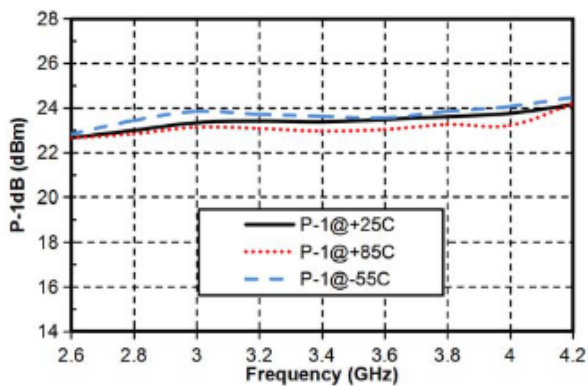

Psat vs. Frequency

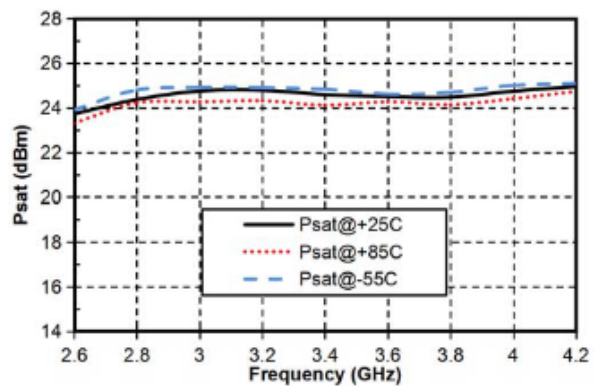



Outline Drawing: All Dimensions in um

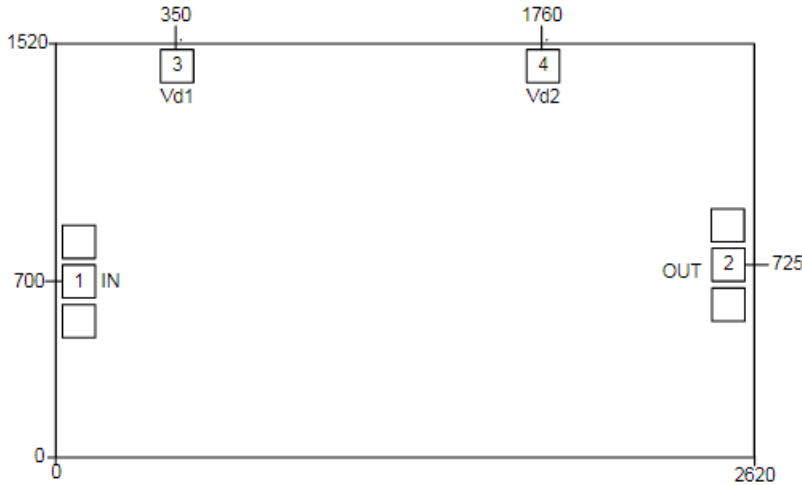

Pad Description

PAD	Function	Description
1	RF IN	RF signal input terminal, no blocking capacitor required
2	RF OUT	RF signal output terminal, no blocking capacitor required
3,4	Vd1, Vd2	Amplifier drain bias, connected to external 100pF, 1000pF 100nF bypass capacitor.
Die Bottom	GND	Die bottom must be connected to RF/DC ground

*Ports 3 and 4 need to be powered on simultaneously



Assembly Drawing

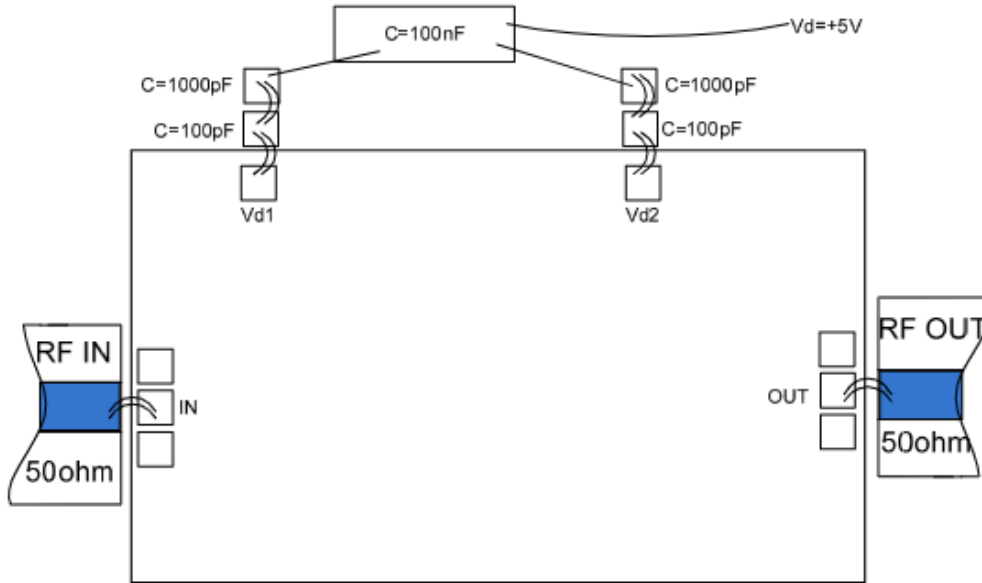

Notes:

1. Die thickness: 100um
2. Typical bond pad is 100*100 μm^2
3. Bond pad metalization: Gold
4. Backside metalization: Gold
5. Backside of the die (GND)
6. No connection required for unlabeled bond pads

Maximum Ratings:

1. Maximum drain voltage: +7V
2. Maximum input power: +20dBm
3. Operating temperature: -55°C to +85°C
4. Storage temperature: -65°C to +150°C