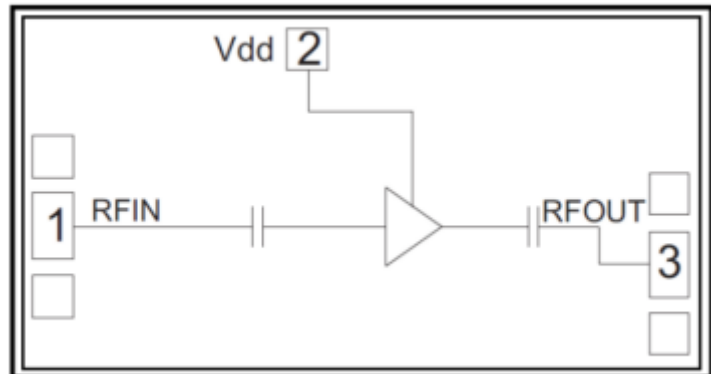

**Features**

- Single Biasing Voltage (Self Biased)
- Frequency: 2-20GHz
- Small Signal Gain: 13dB
- Gain Flatness:  $\leq \pm 1.0$ dB
- Noise figure: 4.5dB
- P1dB: 24dBm
- Psat: 25dBm
- Power Supply: +8V@185mA
- Input/Output: 50Ω
- Die Size: 2.6 x 1.65 x 0.1 mm

**Typical Applications**

- Test Instrumentation
- Microwave Radio & VSAT
- Military & Space
- Telecom Infrastructure
- Fiber Optics

**Functional Block Diagram**

**Electrical Specifications**

TA = +25°C, Vd = +5V

Parameters	Min.	Typ.	Max.	Units
Frequency	2-20			GHz
Small Signal Gain	12	13	14	dB
Gain Flatness		$\pm 1.0$		dB
Noise figure		4.5	5.5	dB
P1dB	22	24	25	dBm
Psat	23	25	26	dBm
Input Return Loss	13	20		dB
Output Return Loss	11	22		dB
Quiescent Current		185		mA

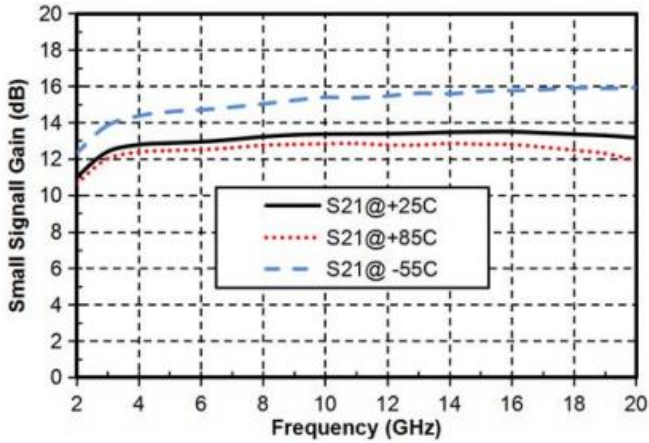

### Gain vs. Frequency



### Reverse Isolation vs. Frequency

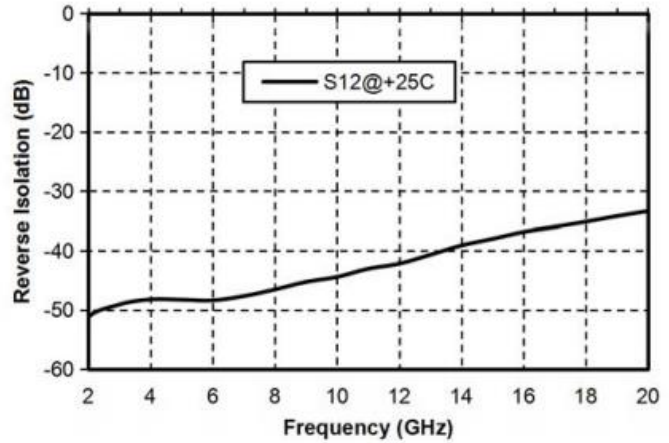

### Input Return Loss vs. Frequency

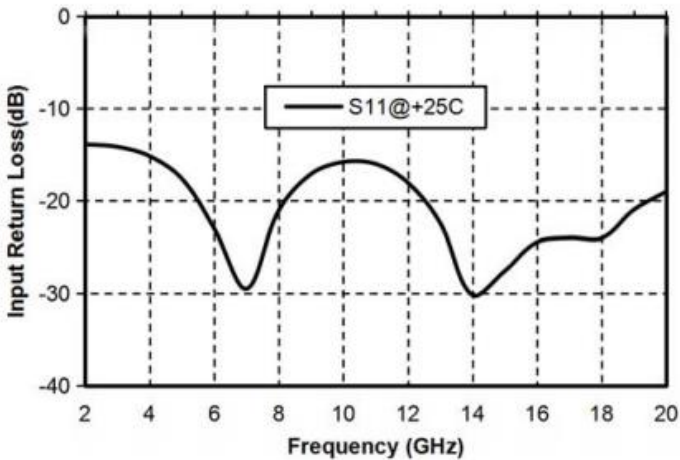

### Output Return Loss vs. Frequency

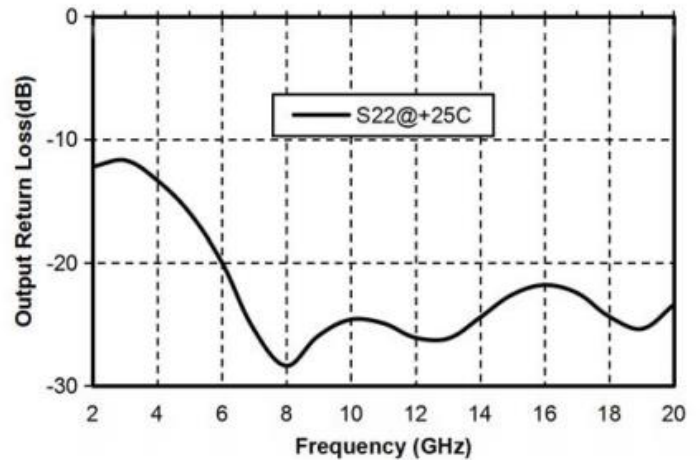

### P-1dB vs. Frequency

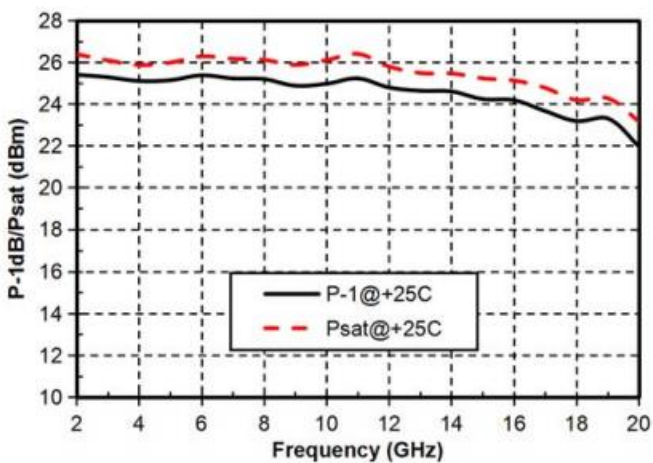



**Outline Drawing:**  
All Dimensions in  $\mu\text{m}$

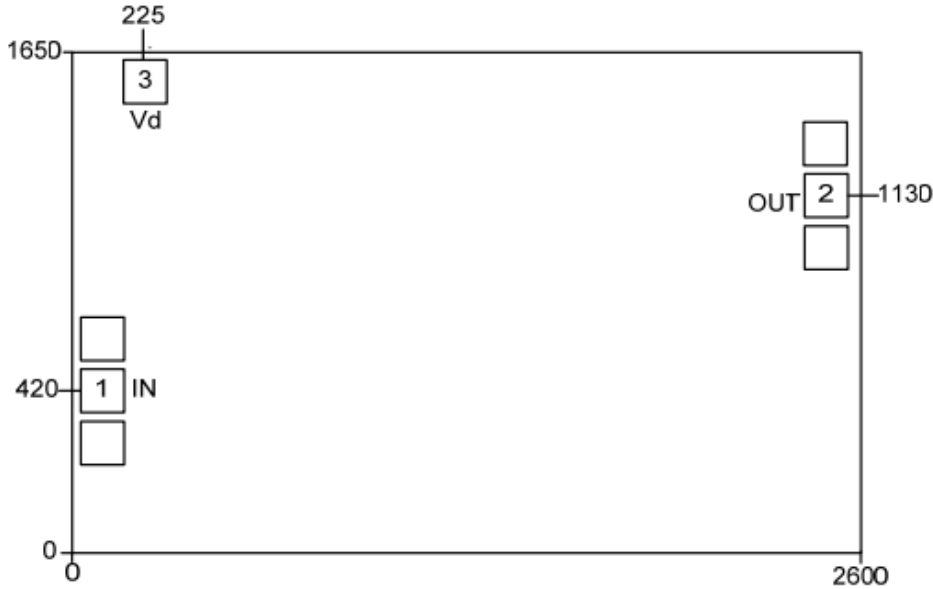

**Pad Description**

PAD	Function	Description	Equivalent Circuit
1	RF IN	RF signal input terminal, no blocking capacitor required	
2	RF OUT	RF signal output terminal, no blocking capacitor required	
3	Vd	Amplifier drain bias, connected to external 100pF bypass capacitor.	
Die Bottom	GND	Die bottom must be connected to RF/DC ground	



### Assembly Drawing

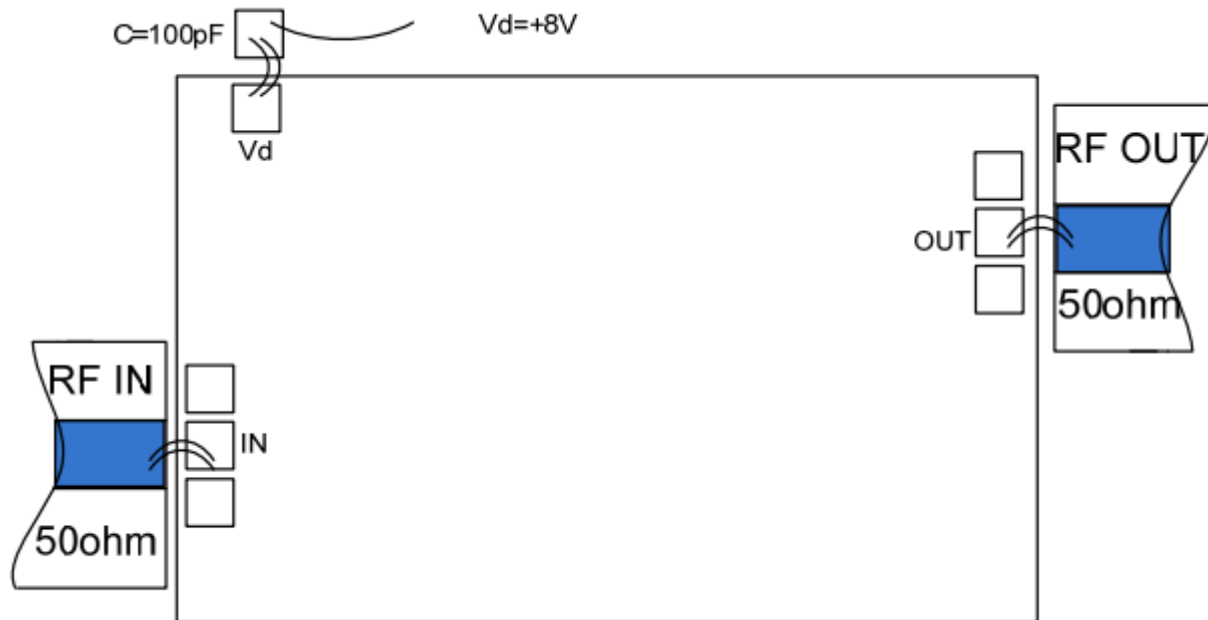

#### Notes:

1. Die thickness: 100um
2. Typical bond pad is 100\*100  $\mu\text{m}^2$
3. Bond pad metalization: Gold
4. Backside metalization: Gold
5. Backside of the die (GND)
6. No connection required for unlabeled bond pads

#### Maximum Ratings:

1. Maximum drain voltage: +10V
2. Maximum input power: +20dBm
3. Operating temperature: -55°C to +85°C
4. Storage temperature: -65°C to +150°C