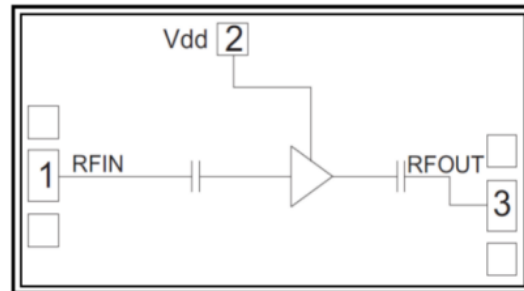

Features

- Single Biasing Voltage (Self Biased)
- Frequency: 5-14GHz
- Small Signal Gain: 22.5dB
- Noise Figure: 1.0dB typ.
- P1dB: 7dBm
- Power Supply: +3.3 V/20 mA
- Input/Output: 50Ω
- Die Size: 1.63 x 1.1 x 0.09 mm

Functional Block Diagram

Typical Applications

- Test Instrumentation
- Microwave Radio & VSAT
- Military & Space
- Telecom Infrastructure
- Fiber Optics

Electrical Specifications
TA = +25°C, Vd = +3.3V

Parameters	Min.	Typ.	Max.	Units
Frequency		5-14		GHz
Small Signal Gain	-	22.5	-	dB
Gain Flatness		±0.7		dB
Noise Figure	-	1.0	1.3	dB
Output 1dB Compression (P1dB)	-	7	-	dBm
Saturated Output Power (Psat)	-	9.5	-	dBm
Input Return Loss	-	18	-	dB
Output Return Loss	-	16	-	dB
Static current		20		mA

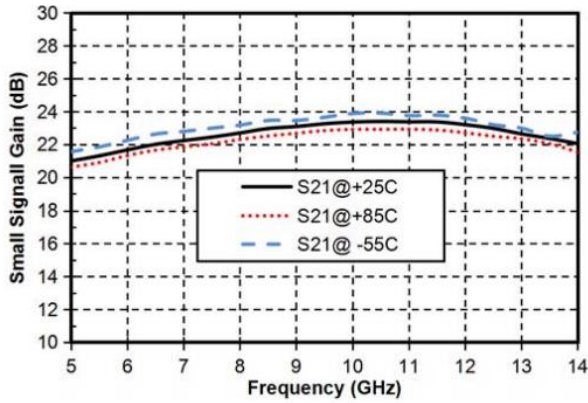
Gain vs. Frequency



Noise Figure vs. Frequency

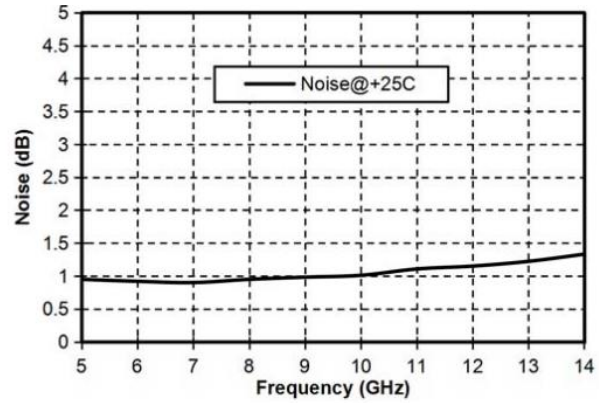

Input Return Loss vs. Frequency

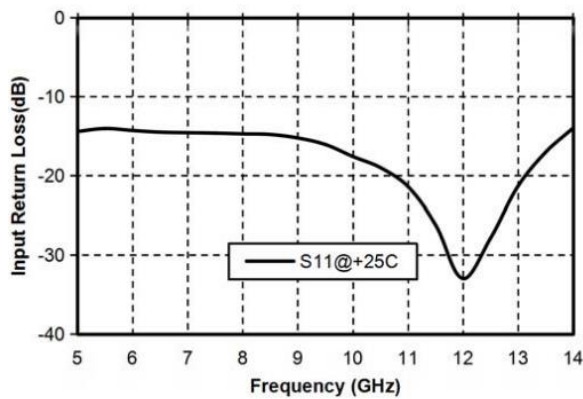

Output Return Loss vs. Frequency

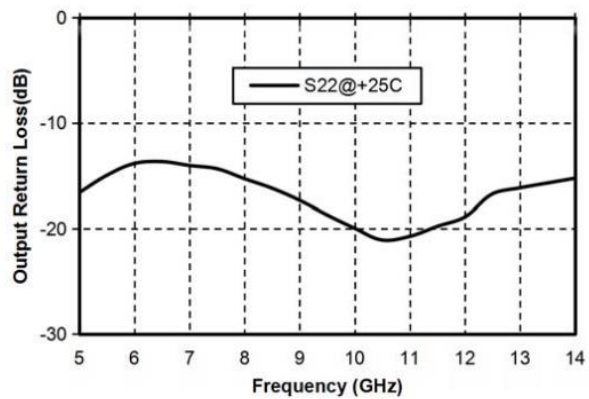

Reverse Isolation vs. Frequency

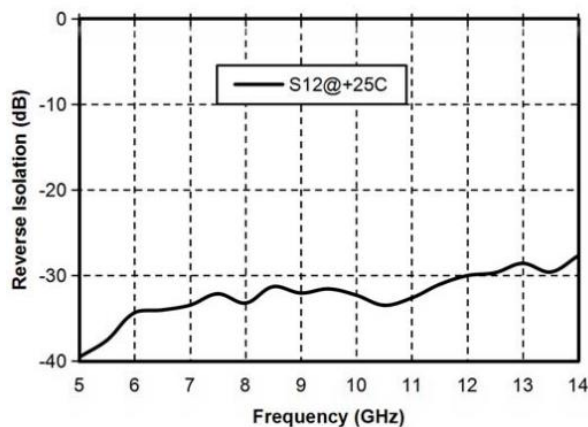

P1dB vs. Temperature

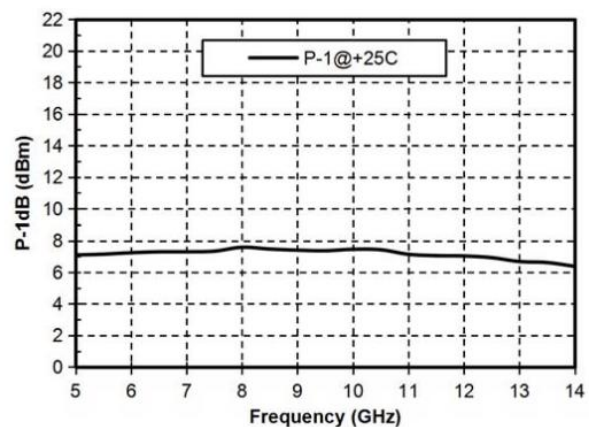



Outline Drawing:
All Dimensions in μm

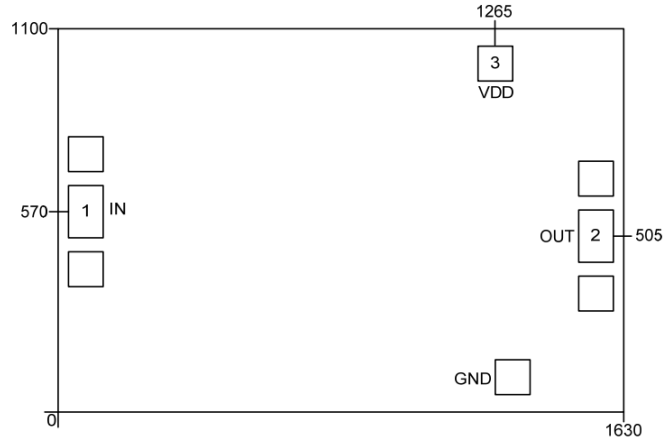

Pad Description

Pad	Function	Description
1	RF IN	RF signal input terminal, no blocking capacitor required.
2	RF OUT	RF signal output terminal, no blocking capacitor required.
3	Vd	Amplifier drain bias; external 100pF bypass capacitor required.
Die bottom	GND	Die bottom must be connected to RF/DC ground.



Assembly Drawing

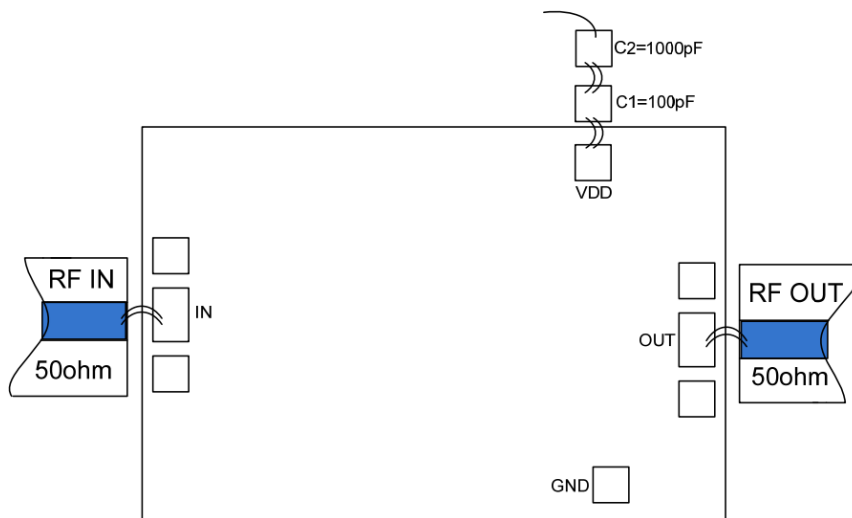

Notes:

1. Die thickness: 100um
2. Typical bond pad is 100*100 μm^2
3. Bond pad metalization: Gold
4. Backside metalization: Gold
5. Backside of the die (GND)
6. No connection required for unlabeled bond pads

Maximum Ratings:

1. Maximum drain voltage: +7V
2. Maximum input power: +20dBm
3. Operating temperature: -55°C to +85°C
4. Storage temperature: -65°C to +150°C