

**Features**

- Single Biasing Voltage(Self Biased)
- Frequency: 2-18GHz
- Small Signal Gain: 24dB(positive slope)
- Noise Figure:1.0dB typ.(Vector Net Test)
- P1dB: 14dBm
- Power supply: +5V@40mA
- Input/Output: 50Ω
- Die Size: 1.6 x 1.2 x 0.1 mm

**Typical Applications**

- Test Instrumentation
- Microwave Radio & VSAT
- Military & Space
- Telecom Infrastructure
- Fiber Optics

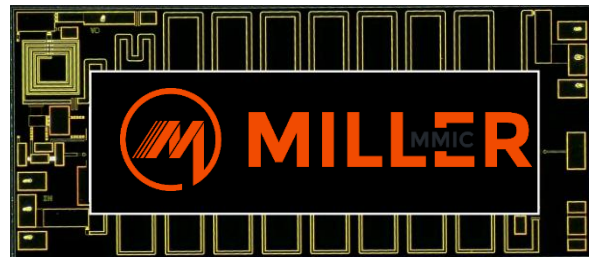

**Electrical Specifications**
**TA = +25°C, Vd = +5V**

Parameters	Min.	Typ.	Max.	Units
<b>Frequency</b>		<b>2-18</b>		<b>GHz</b>
<b>Small Signal Gain</b>	-	<b>24</b>	-	<b>dB</b>
<b>Gain Flatness</b>		<b>±1.6</b>		<b>dB</b>
<b>Noise Figure (Vector Net)</b>	-	<b>1.0</b>	-	<b>dB</b>
<b>Noise Figure (Noise Meter)</b>		<b>1.1</b>		<b>dB</b>
<b>Output 1dB Compression (P1dB)</b>	-	<b>14</b>	-	<b>dBm</b>
<b>Psat</b>	-	<b>15</b>	-	<b>dBm</b>
<b>Input Return Loss</b>	-	<b>22</b>	-	<b>dB</b>
<b>Output Return Loss</b>	-	<b>15</b>	-	<b>dB</b>
<b>Static current</b>	-	<b>40</b>	-	<b>mA</b>

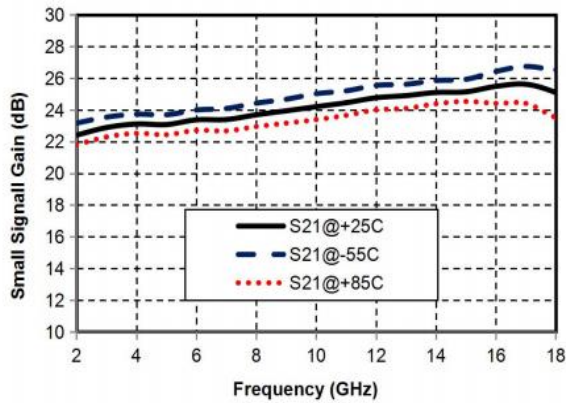
### Gain vs. Frequency

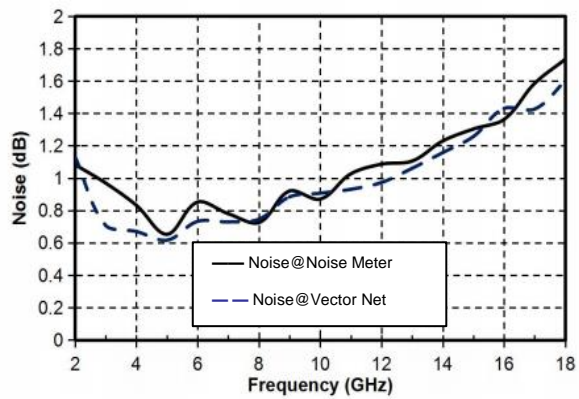

### Noise Figure vs. Frequency



### Input Return Loss vs. Frequency

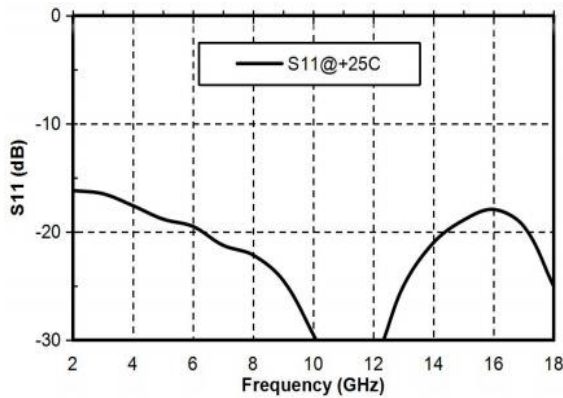

### Output Return Loss vs. Frequency

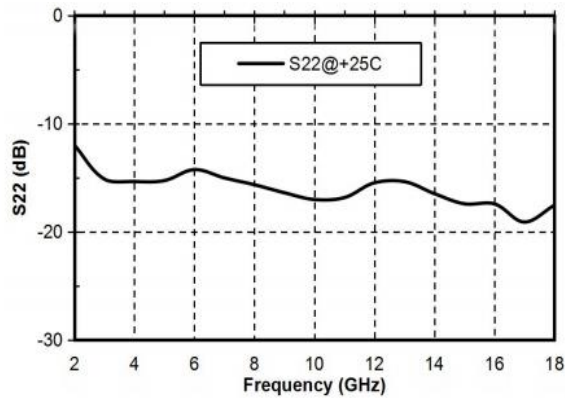

### Reverse Isolation vs. Frequency

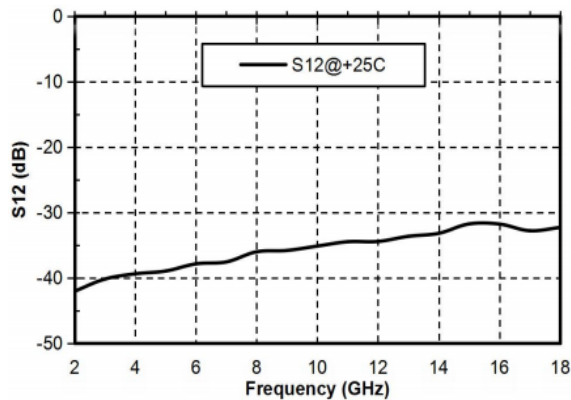

### P1dB vs. Frequency

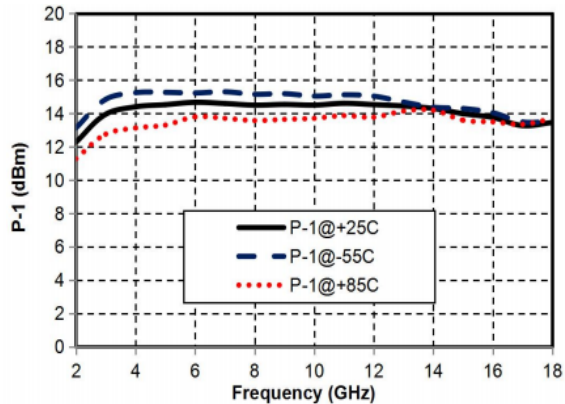



### Outline Drawing:

All Dimensions in  $\mu\text{m}$

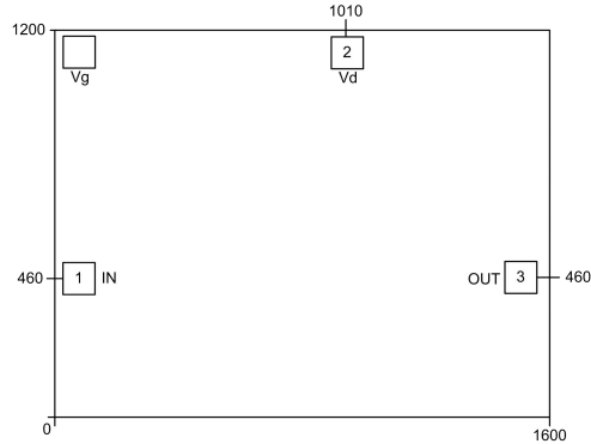

### Pad Description

Pad	Function	Description
1	RF IN	RF signal input terminal, no blocking capacitor required.
3	RF OUT	RF signal output terminal, no blocking capacitor required.
2	VDD	Amplifier drain bias; external 100pF, 1000pF bypass capacitor required.
Die bottom	GND	Die bottom must be connected to RF/DC ground.



### Assembly Drawing

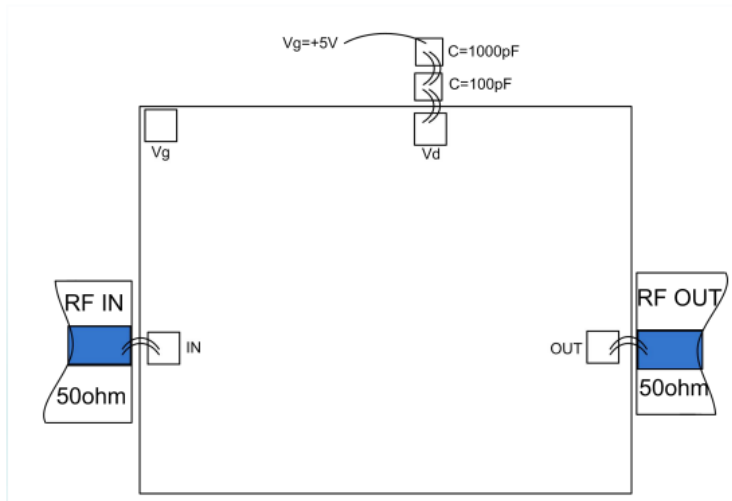

#### Notes:

1. Die thickness: 100um
2. Typical bond pad is 100\*100  $\mu\text{m}^2$
3. Bond pad metalization: Gold
4. Backside metalization: Gold
5. Backside of the die (GND)
6. No connection required for unlabeled bond pads

#### Maximum Ratings:

1. Maximum drain voltage: +7V
2. Maximum input power: +20dBm
3. Operating temperature: -55°C to +85°C
4. Storage temperature: -65°C to +150°C