

Features

- Frequency: 4-8GHz
- Small Signal Gain: 24.5dB
- Noise Figure: 1.1dB
- P1dB: 18.5dBm
- Power supply: +5V/85mA
- Input/Output: 50Ω
- Die Size: 1.68 x 0.88 x 0.1 mm

Typical Applications

- Test Instrumentation
- Microwave Radio & VSAT
- Military & Space
- Telecom Infrastructure
- Fiber Optics



Electrical Specifications

TA = +25°C, Vd = +5V

Parameters	Min.	Typ.	Max.	Units
Frequency		4-8		GHz
Small Signal Gain	-	24.5	-	dB
Gain Flatness	-	±0.1	-	dB
Noise Figure	-	1.1	-	dB
Output 1dB Compression (P1dB)	-	18.5	-	dBm
Psat		19		dBm
Input Return Loss	-	14	-	dB
Output Return Loss	-	22	-	dB
Static current	-	85	-	mA
Reverse Isolation	-	33	-	dB
*The noise figure test instrument is N5245B.				

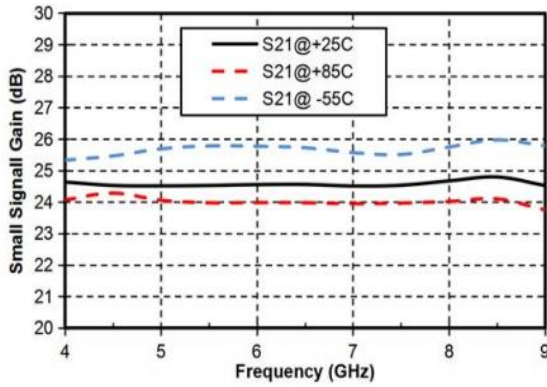

Gain vs. Frequency



Noise Figure vs. Frequency

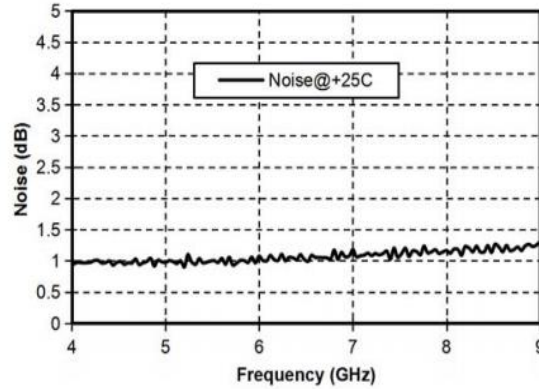

Input Return Loss vs. Frequency

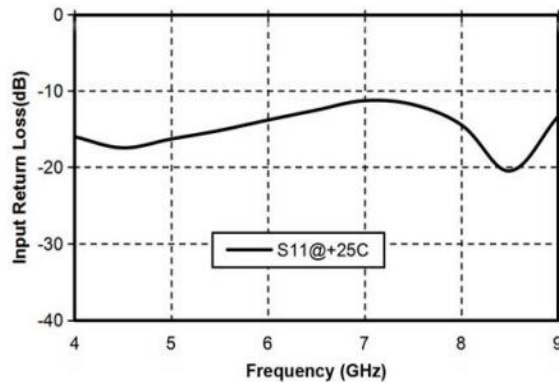

Output Return Loss vs. Frequency

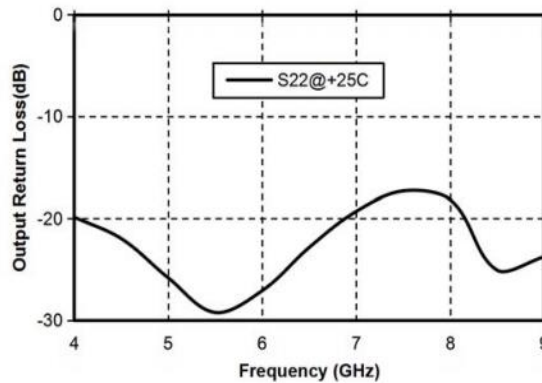

Reverse Isolation vs. Frequency

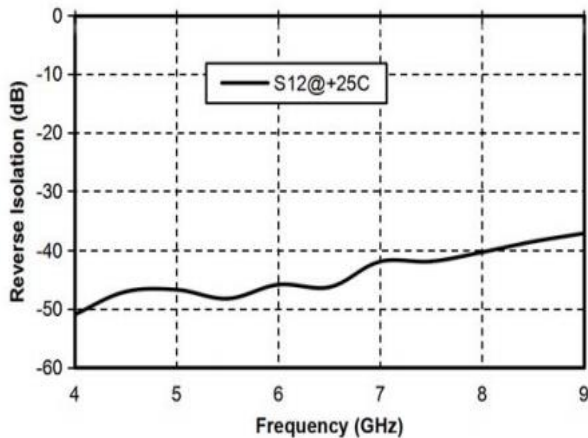

P1dB/Psat vs. Frequency

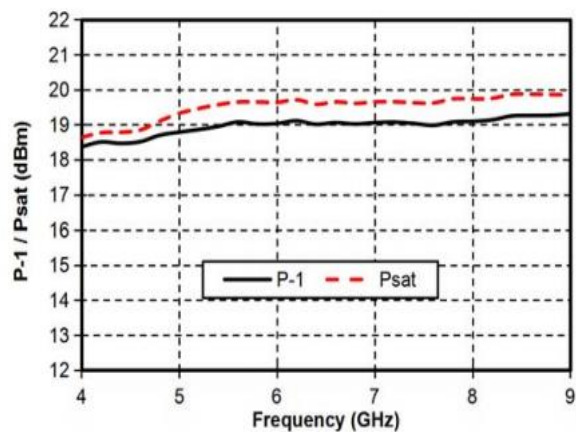



Outline Drawing:
All Dimensions in μm

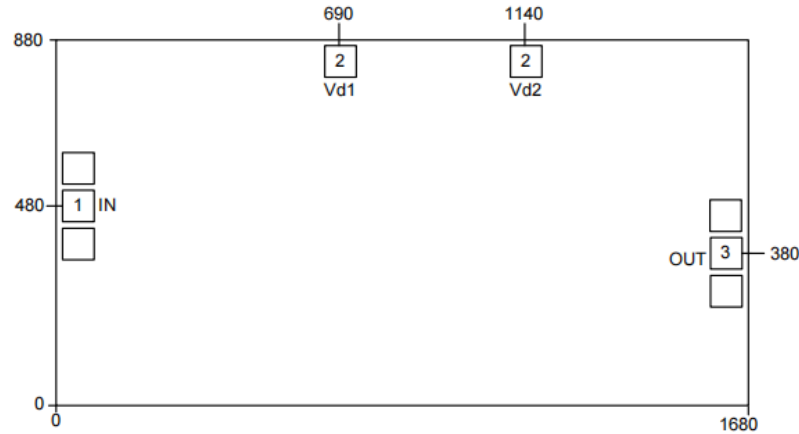

Pad Description

Pad	Function	Description
1	RF IN	RF signal input terminal, no blocking capacitor required.
3	RF OUT	RF signal output terminal, no blocking capacitor required.
2	VDD	Amplifier drain bias; external 100pF bypass capacitor required.
Die bottom	GND	Die bottom must be connected to RF/DC ground.



Assembly Drawing

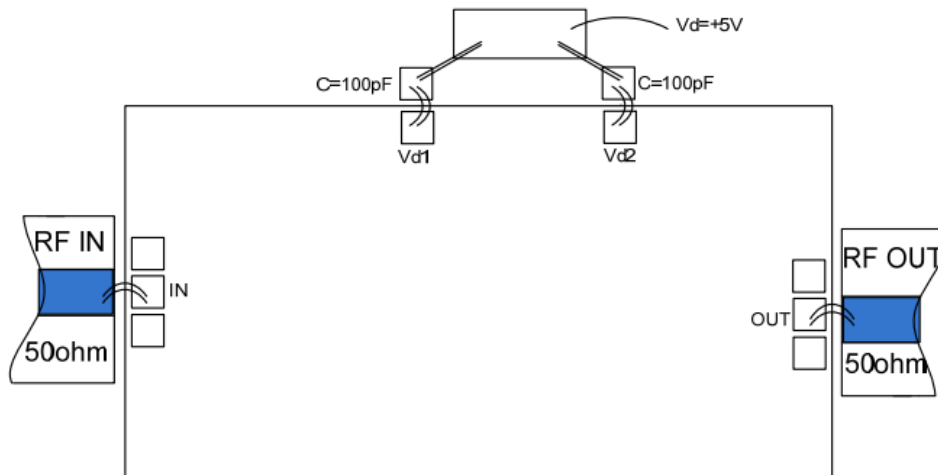

Notes:

1. Die thickness: 100um
2. Typical bond pad is 100*100 μm^2
3. Bond pad metalization: Gold
4. Backside metalization: Gold
5. Backside of the die (GND)
6. No connection required for unlabeled bond pads

Maximum Ratings:

1. Maximum drain voltage: +8V
2. Maximum input power: +20dBm
3. Operating temperature: -55°C to +85°C
4. Storage temperature: -65°C to +150°C