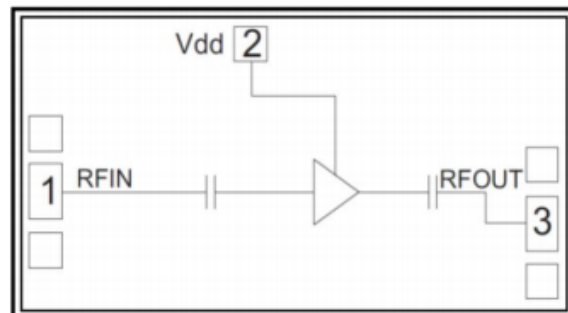

Features

- Single Biasing Voltage(Self Biased)
- Frequency: 6-18GHz
- Small Signal Gain: 20dB
- Noise Figure: 1.5dB typ.
- P1dB: 17dBm
- Power supply: +3.5V/90mA
- Input/Output: 50Ω
- Die Size: 1.6 x 0.8 x 0.09 mm

Typical Applications

- Test Instrumentation
- Microwave Radio & VSAT
- Military & Space
- Telecom Infrastructure
- Fiber Optics

Functional Block Diagram

Electrical Specifications
TA = +25°C, Vd = +3.5V

Parameters	Min.	Typ.	Max.	Units
Frequency		6-18		GHz
Small Signal Gain		20		dB
Gain Flatness		±1.25		dB
Noise Figure		1.5		dB
Output 1dB Compression (P1dB)		17		dBm
Psat		18		dBm
Input Return Loss		16		dB
Output Return Loss		24		dB
Static current		90		mA

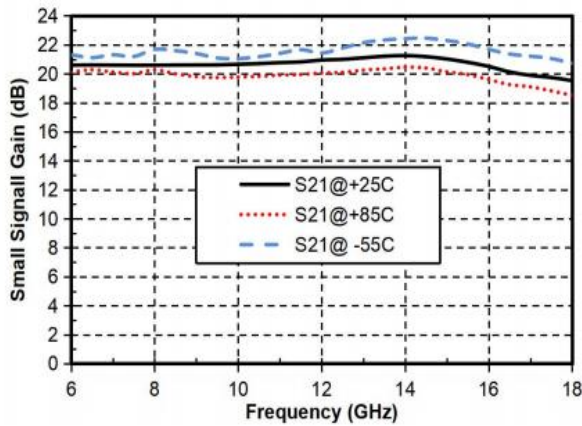
Gain vs. Frequency

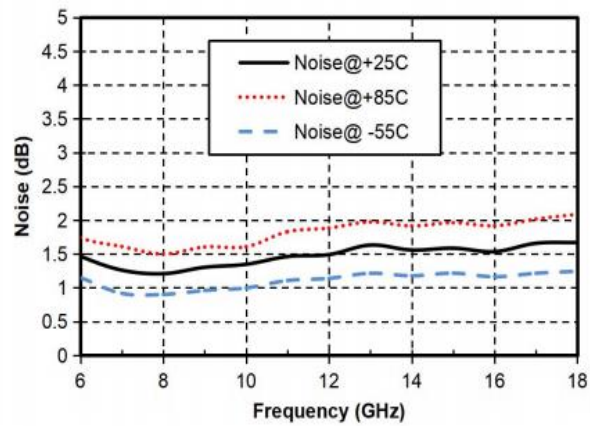

Noise Figure vs. Frequency



Input Return Loss vs. Frequency

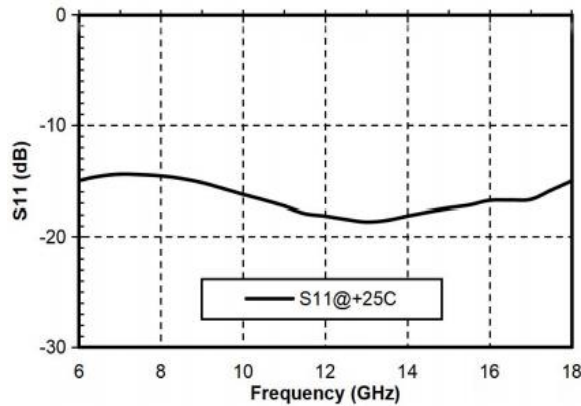

Output Return Loss vs. Frequency

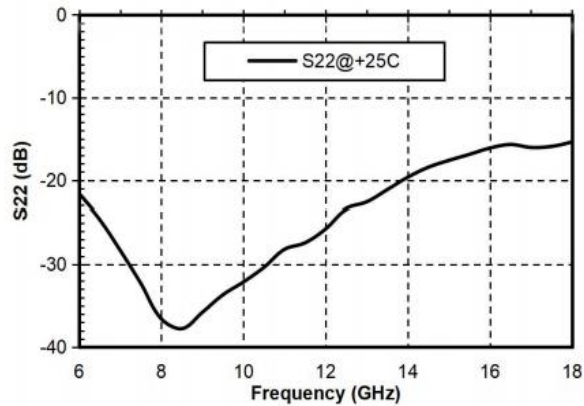

Reverse Isolation vs. Frequency

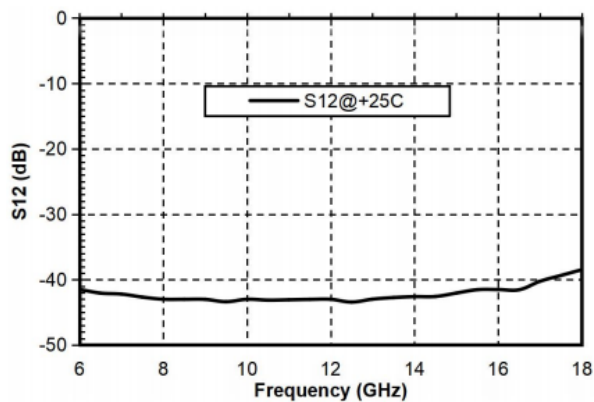

P1dB vs. Frequency

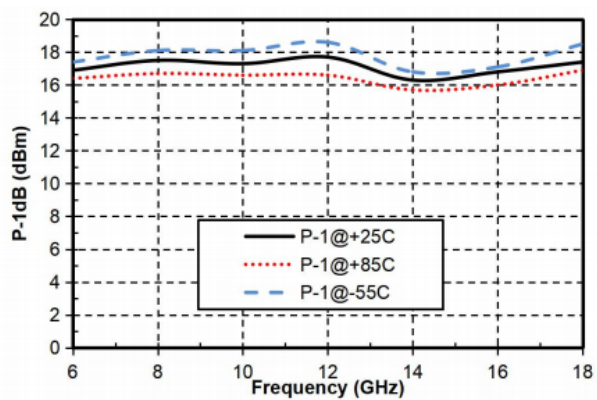



Outline Drawing:
All Dimensions in μm

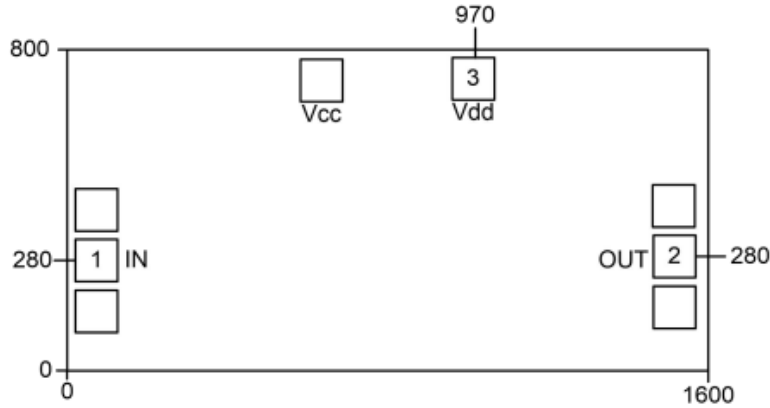

Pad Description

Pad	Function	Description	Equivalent Circuit
1	RF IN	RF signal input terminal, no blocking capacitor required.	
2	RF OUT	RF signal output terminal, no blocking capacitor required.	
3	VDD	Amplifier drain bias; external 100pF bypass capacitor required.	
Die bottom	GND	Die bottom must be connected to RF/DC ground.	



Assembly Drawing

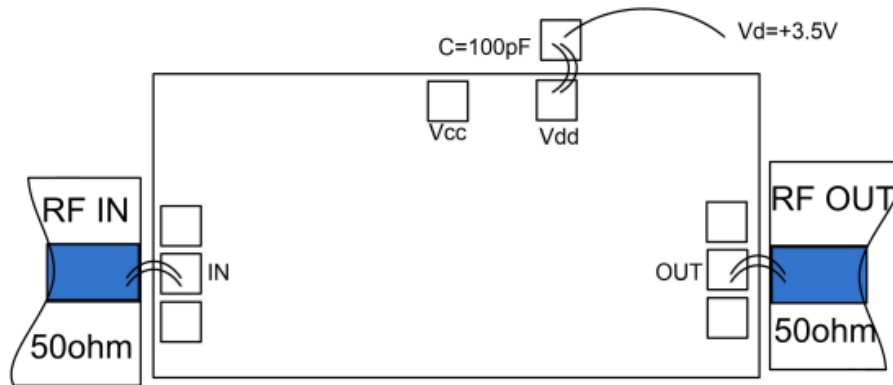

Notes:

1. Die thickness: 100um
2. Typical bond pad is 100*100 μm^2
3. Bond pad metalization: Gold
4. Backside metalization: Gold
5. Backside of the die (GND)
6. No connection required for unlabeled bond pads

Maximum Ratings:

1. Maximum drain voltage: +5V
2. Maximum input power: +20dBm
3. Operating temperature: -55°C to +85°C
4. Storage temperature: -65°C to +150°C