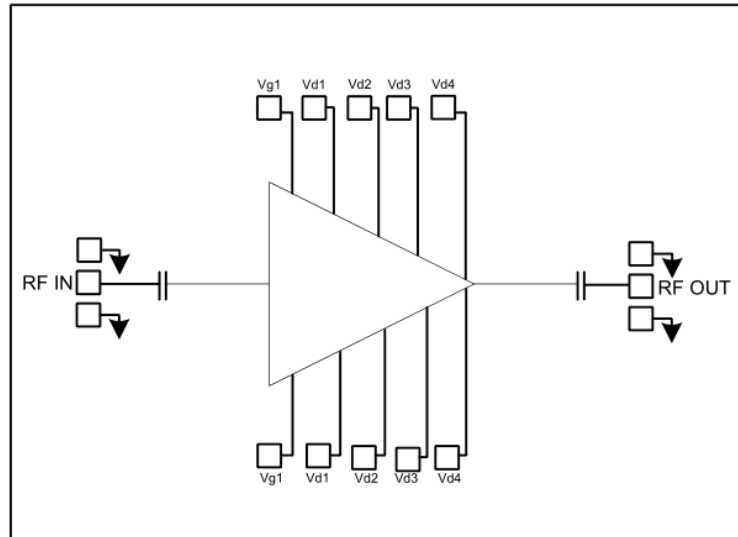

Features

- Frequency: 15-17GHz
- Small Signal Gain: 35dB
- Power Gain: 32dB
- Psat: 37dBm
- PAE: 32%
- Power Supply: +7V/1400mA
- Input/Output: 50Ω
- Die Size: 3.7 x 3.35 x 0.1 mm

Typical Applications

- Test Instrumentation
- Microwave Radio & VSAT
- Military & Space
- Telecom Infrastructure
- Fiber Optics

Functional Block Diagram

Electrical Specifications

TA = +25°C, Vd = +7V, Ids=1400mA

Parameters	Min.	Typ.	Max.	Units
Frequency	15-17			GHz
Small Signal Gain	34.5	35	35.5	dB
Gain Flatness	±0.5			dB
Output 1dB Compression (P1dB)	36.5	37	37.5	dBm
Psat	36.8	37	37.5	dBm
Input Return Loss	-	28	-	dB
Output Return Loss	-	32	-	dB
* Adjust VG (-2V-0V) to obtain device current of 1400mA. (Recommended gate voltage -0.9V).				

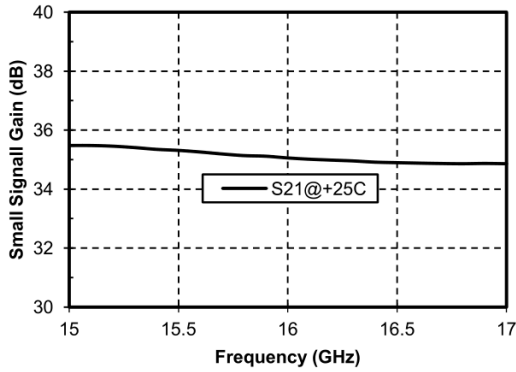

Gain vs. Frequency



Reverse Isolation vs. Frequency

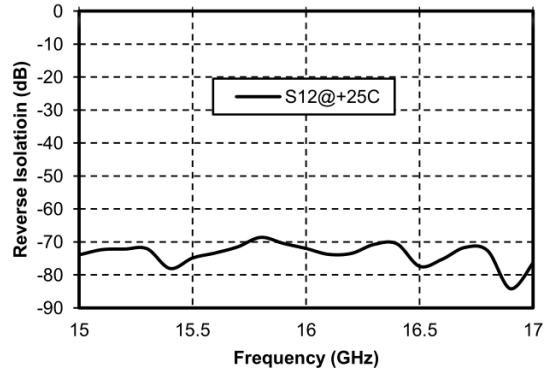

Input Return Loss vs. Frequency

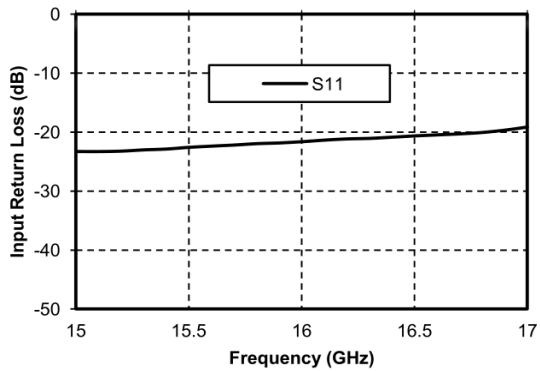

Output Return Loss vs. Frequency

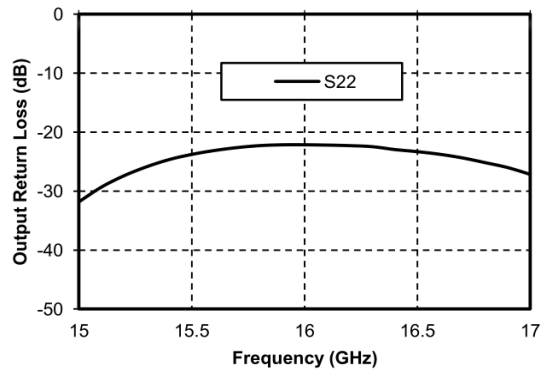

P1dB vs. Frequency

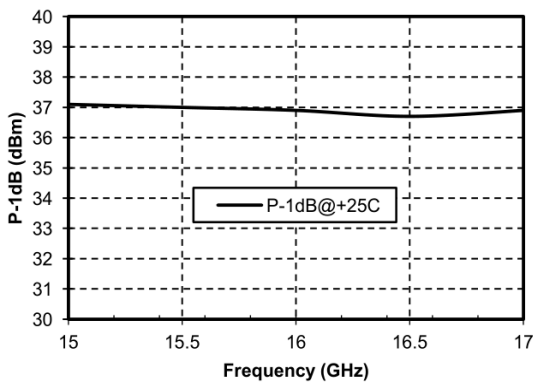

Psat vs. Frequency

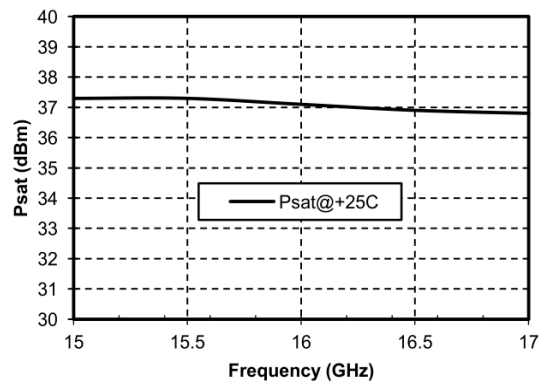



Outline Drawing:

All Dimensions in μm

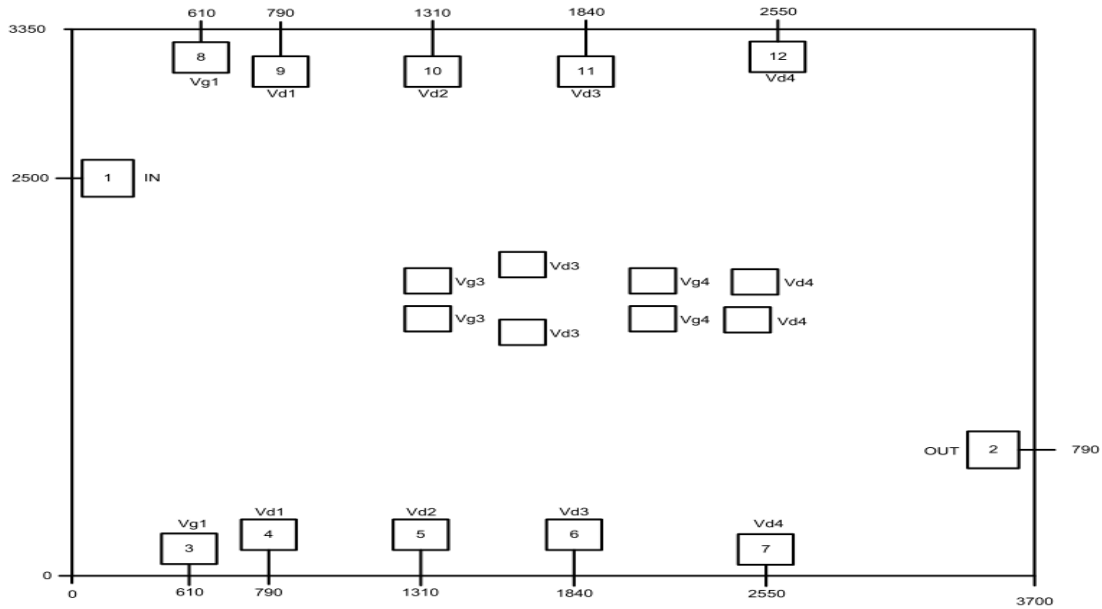

Pad Description

Pad	Function	Description	Equivalent Circuit
1	RF IN	Signal input terminal, connected to 50 Ω circuit; no blocking capacitor required.	
2	RF OUT	Signal output terminal, connected to 50 Ω circuit; no blocking capacitor required.	
4, 5, 6, 7, 9, 10, 11, 12	Vd1-4	Amplifier drain bias; external 1000pF bypass capacitor required.	
3, 8	Vg1-2	Amplifier gate bias; external 1000pF bypass capacitor required.	
Die bottom	GND	Die bottom must be connected to RF/DC ground.	



Assembly Drawing

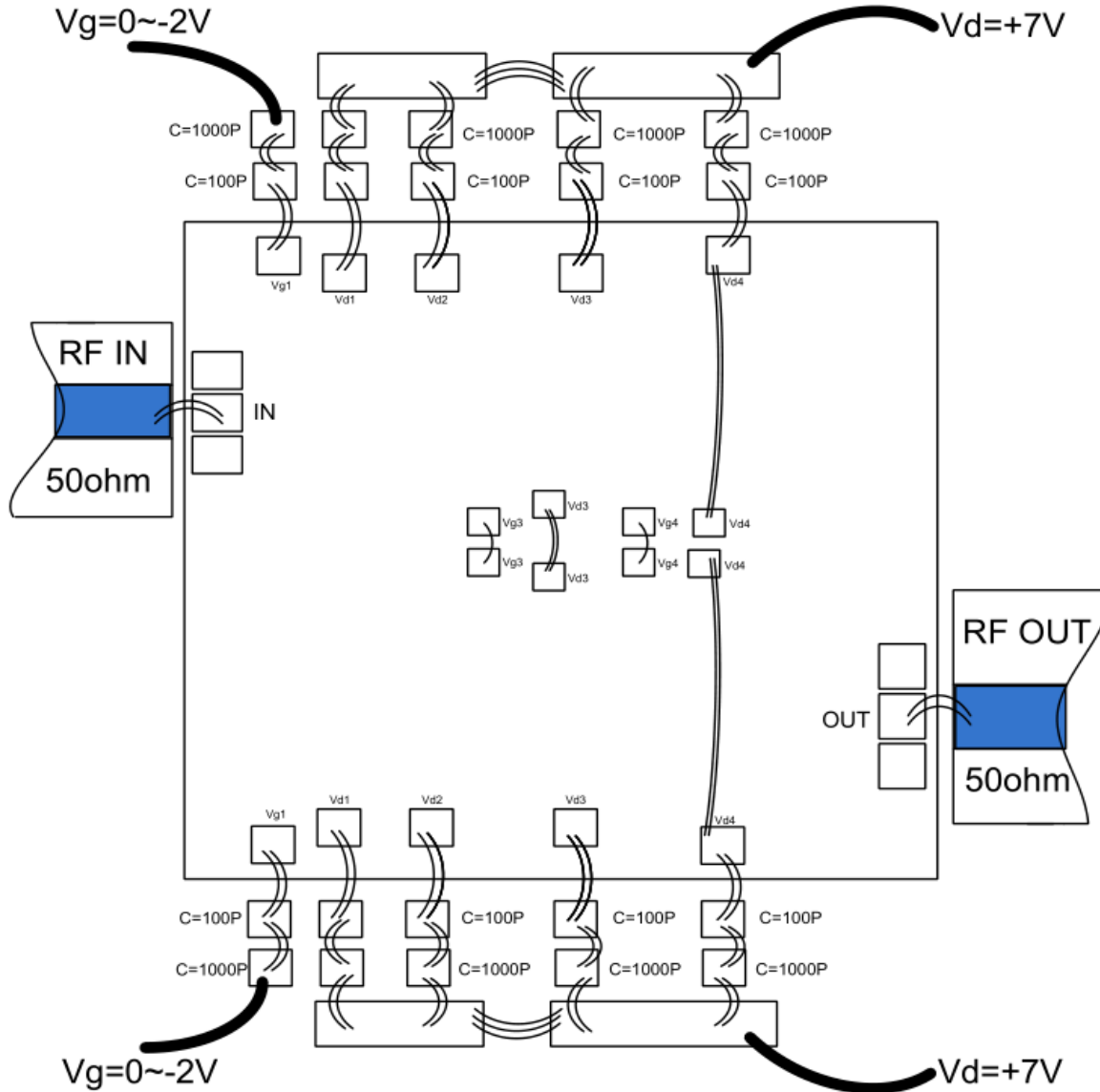

Notes:

1. Die thickness: 100um
2. Typical bond pad is 100*100 μm^2
3. Bond pad metalization: Gold
4. Backside metalization: Gold
5. Backside of the die (GND)
6. No connection required for unlabeled bond pads

Maximum Ratings:

1. Maximum drain voltage: +8V
2. Maximum gate bias: -5V
3. Maximum input power: +10dBm
4. Operating temperature: -55°C to +85°C
5. Storage temperature: -65°C to +150°C