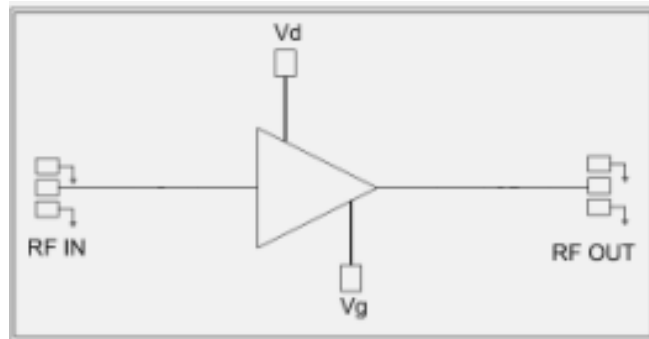

Features

- Frequency: DC-30GHz
- Small Signal Gain: 16dB
- Gain Flatness: $\leq \pm 0.2\text{dB}@DC-26\text{GHz}$
- Noise Figure: $\leq 4\text{dB}$
- P1dB: 26dBm
- Psat: 27dBm
- Power supply: +8V/180mA
- Input/Output: 50 Ω
- Die Size: 2.94 x 1.35 x 0.1 mm

Functional Block Diagram

Typical Applications

- Test Instrumentation
- Microwave Radio & VSAT
- Military & Space
- Telecom Infrastructure
- Fiber Optics

Electrical Specifications
TA = +25°C, Vd = +8V, *Ids=180mA

Parameters	Min.	Typ.	Max.	Min.	Typ.	Max.	Min.	Typ.	Max.	Units
Frequency	DC-18			18-26			26-30			GHz
Small Signal Gain	15.9	16	16.1	16	16	16.2	16	15	14.8	dB
Gain Flatness		± 0.2			± 0.2			± 0.9		dB
Noise Figure	2.0	2.5	3.9	3.1	4.0	5.1	5.1	6.0	6.1	dB
Output 1dB Compression (P1dB)	25.9	26	27.3	25.2	25	26.2	25.2	24	24.2	dBm
Saturated Output Power (Psat)	26.9	27	28.3	26	26.5	27	26	25.5	25.2	dBm
Input Return Loss		15			18			15		dB
Output Return Loss		20			16			13		dB

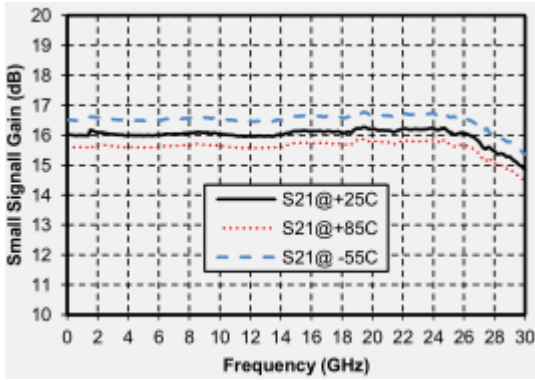
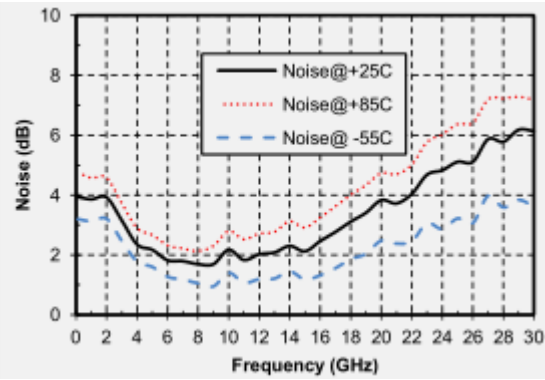
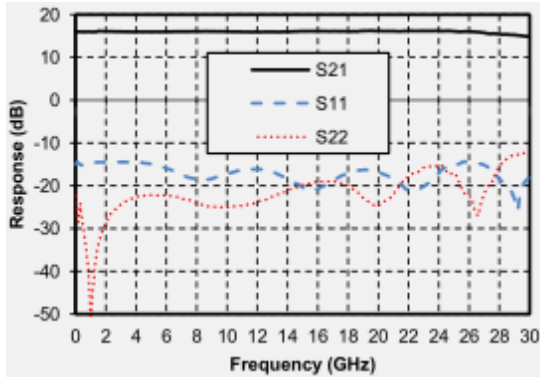
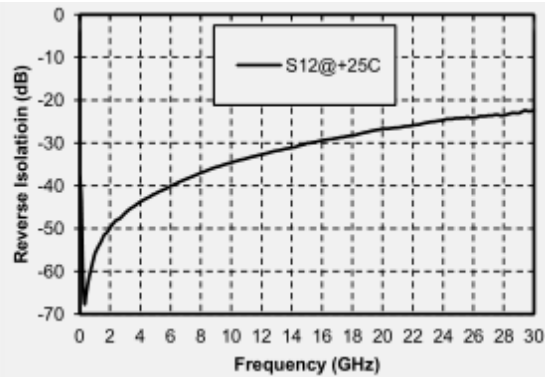
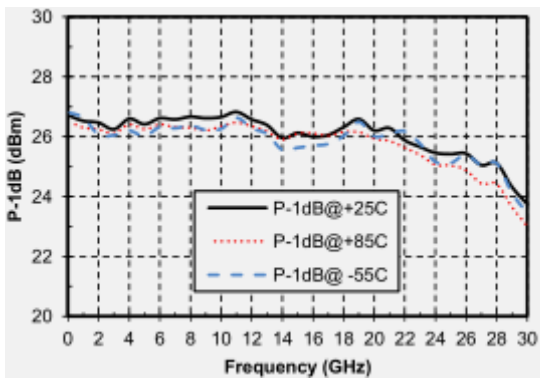
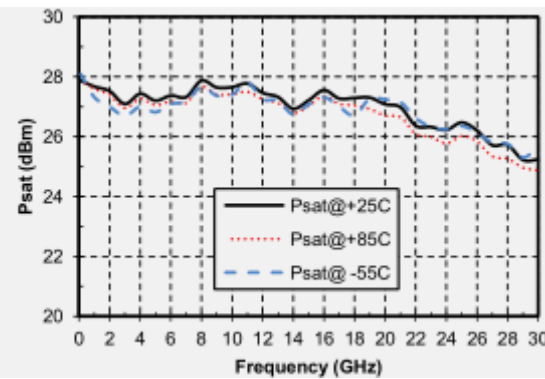
*** Adjust VG (-2V-0V) to obtain device current of 180mA. (Approximately -0.6V)**

Gain vs. Frequency

Noise Figure vs. Frequency

Gain & Return Loss vs. Frequency

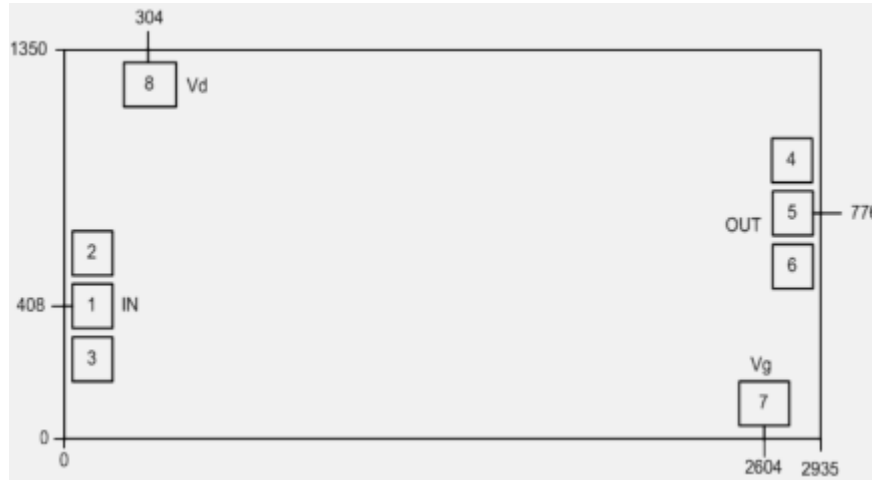
Reverse Isolation vs. Frequency

P1dB vs. Frequency

Psat vs. Frequency



Outline Drawing:
All Dimensions in μm



Pad Description

Pad	Function	Description	Equivalent Circuit
1	RF IN	Signal input terminal, connected to 50Ω circuit; blocking capacitor required.	
5	RF OUT	Signal output terminal, connected to 50Ω circuit; blocking capacitor required; external DC biasing network required; drain current provided. Refer to following assembly drawing or contact manufacturer.	
7	Vg	Amplifier gate bias; connected to 100pF bypass capacitor.	
8	Vd	Amplifier drain bias; connected to external 100pF bypass capacitor.	
2, 3, 4, 6, die bottom	GND	Die bottom must be connected to RF/DC ground.	



Assembly Drawing

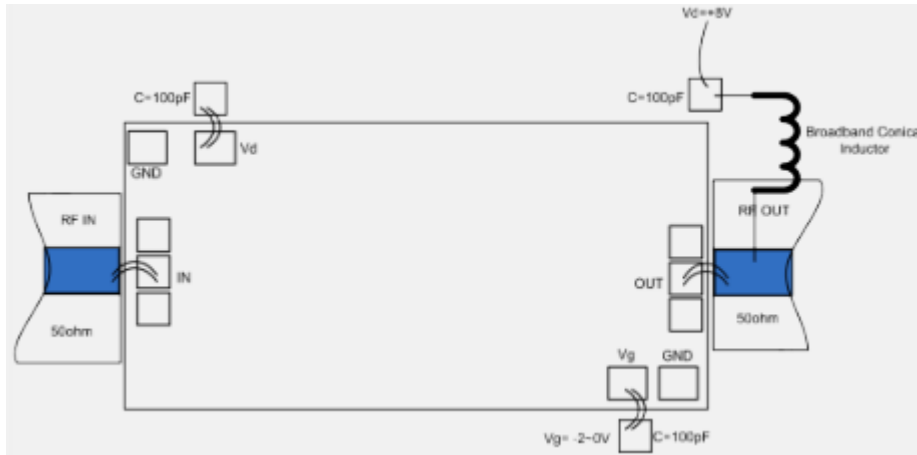

Notes:

1. Die thickness: 100um
2. Typical bond pad is 100*100 μm^2
3. Bond pad metalization: Gold
4. Backside metalization: Gold
5. Backside of the die (GND)
6. No connection required for unlabeled bond pads

Maximum Ratings:

1. Maximum drain voltage: +14V
2. Maximum gate bias: -3V
3. Maximum input power: +20dBm
4. Operating temperature: -55°C to +85°C
5. Storage temperature: -65°C to +150°C