



Features

- Frequency: DC-15GHz
- Small Signal Gain: 18dB
- P1dB: 25.5dB
- Psat: 26.5dBm
- Power Supply: +8V/270mA
- Input/Output: 50Ω
- Die Size: 3.12 x 1.62 x 0.1 mm

Typical Applications

- Test Instrumentation
- Microwave Radio & VSAT
- Military & Space
- Telecom Infrastructure
- Fiber Optics

Electrical Specifications

TA = +25°C, Vd = +8V, Ids=270mA

Parameters	Min.	Typ.	Max.	Units
Frequency	DC-15			GHz
Small Signal Gain		18		dB
Gain Flatness	±1.6			dB
Output 1dB Compression (P1dB)		25.5		dBm
Saturated Output Power (Psat)		26.5		dBm
Input Return Loss		19		dB
Output Return Loss		22		dB
By tuning the Vg terminal voltage -2V~0V, the Vg terminal voltage is recommended to -0.65V.				

Gain vs. Frequency

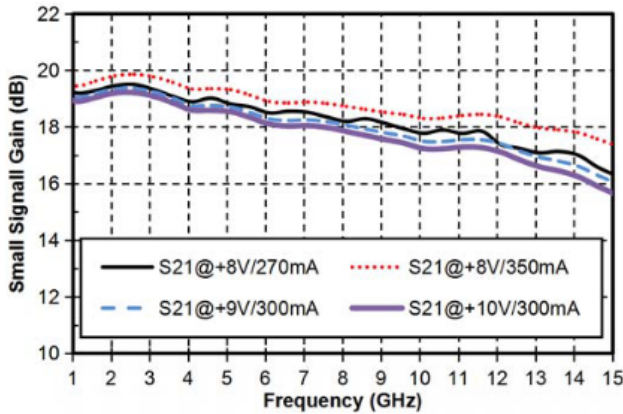

Reverse Isolation vs. Frequency

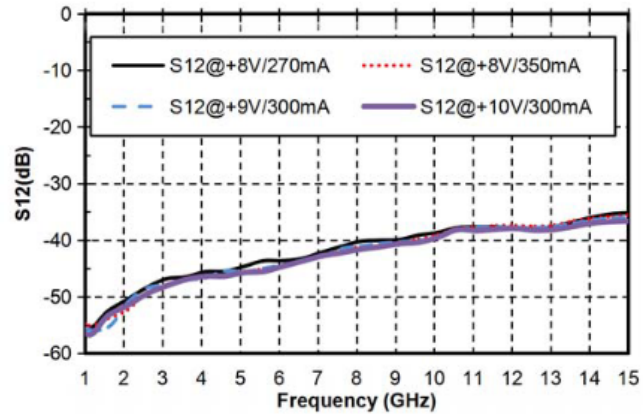

Input Return Loss vs. Frequency

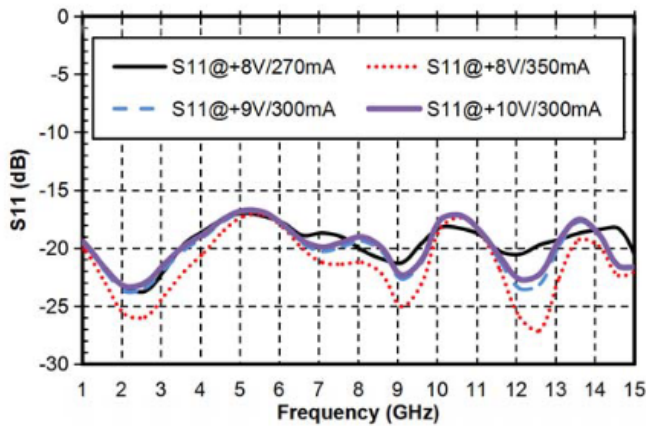

Output Return Loss vs. Frequency

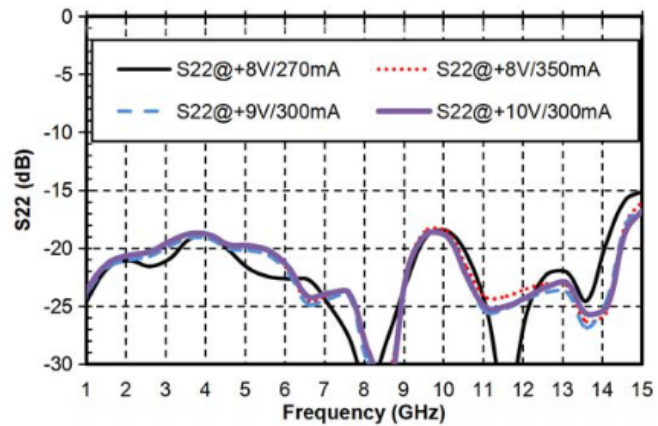

P1 vs. Frequency

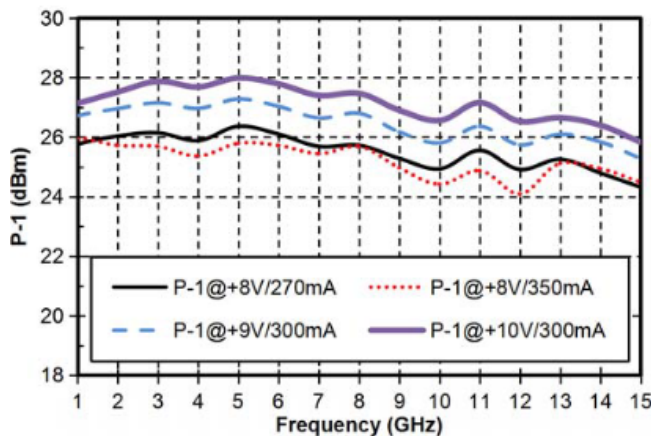

Psat vs. Frequency

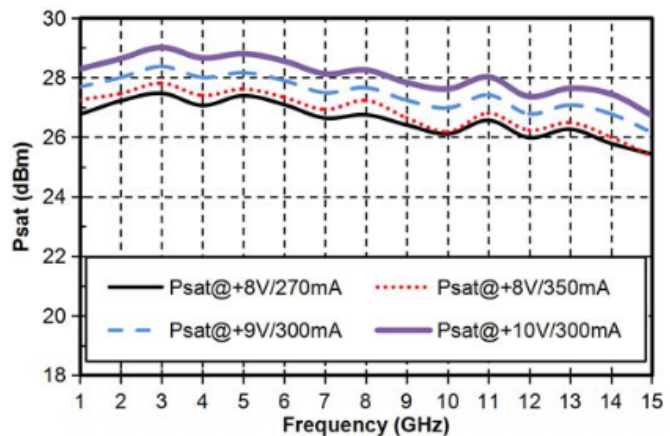



Outline Drawing:
All Dimensions in μm

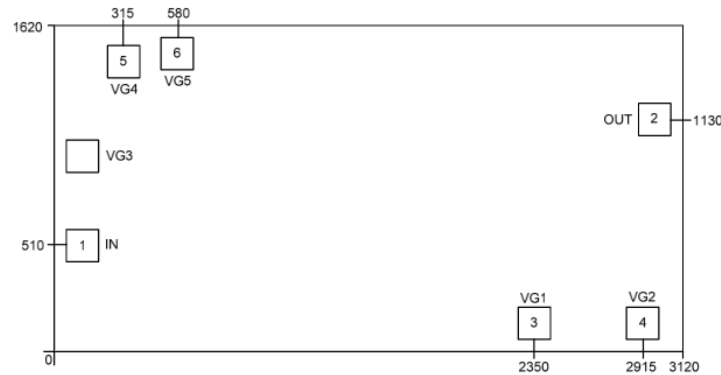

Pad Description

Pad	Function	Description
1	RF IN	Signal input terminal, connected to 50 Ω circuit; no blocking capacitor required.
2	RF OUT, VD	Signal output terminal, connected to 50 Ω circuit; blocking capacitor required. External DC bias network to provide drain current. Please refer to the following application circuits or contact the manufacturer
3	VG1	Amplifier drain bias, connected to external wide-band inductor and 100pF, 0.1uF bypass capacitor
4,5,6	VG2, VG4, VG5	Connect ground and connected to external wide-band inductor and 100pF bypass capacitor.
Die bottom	GND	Die bottom must be connected to RF/DC ground.



Assembly Drawing

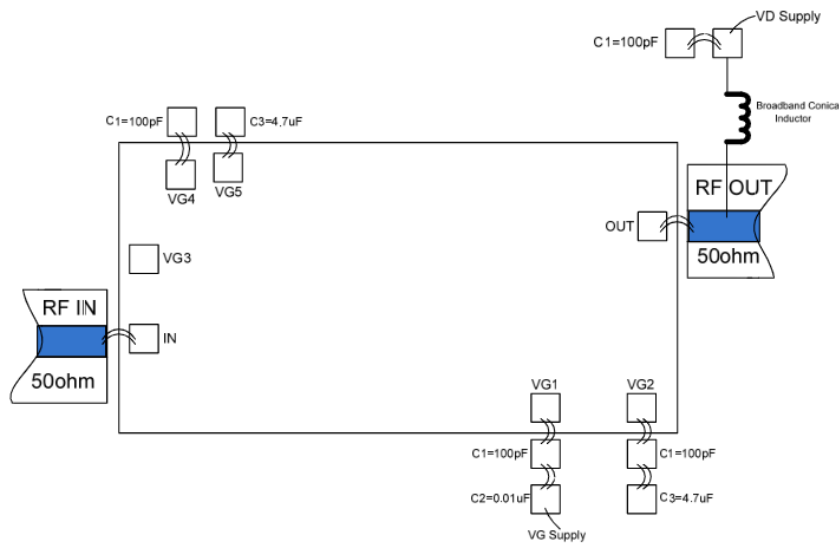

Notes:

1. Die thickness: 100um
2. Typical bond pad is 100*100 μm^2
3. Bond pad metalization: Gold
4. Backside metalization: Gold
5. Backside of the die (GND)
6. No connection required for unlabeled bond pads

Maximum Ratings:

1. Maximum drain voltage: +7V
2. 3. Maximum input power: +20dBm
4. Operating temperature: -55°C to +85°C
5. Storage temperature: -65°C to +150°C