



Features

- Frequency: 6-18GHz
- Insertion Loss: 1.0dB
- Input/Output: 50Ω
- Chip Size: 1.824 x 1.047 x 0.1mm

Typical Applications

- Test Instrumentation
- Microwave Radio & VSAT
- Military & Space
- Telecom Infrastructure
- Fiber Optics

Electrical Specifications

TA = +25°C

Parameters	Min.	Typ.	Max.	Units
Frequency	6		18	GHz
Insertion Loss		1.0		dB
Flatness		±0.4		dB
Isolation	17	22		dB
Input Return Loss	12	15		dB
Output Return Loss	18	21		dB

Functional Block Diagram

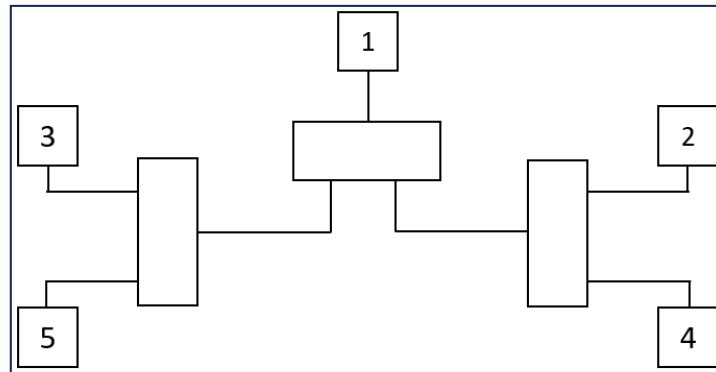

Insertion Loss vs. Frequency

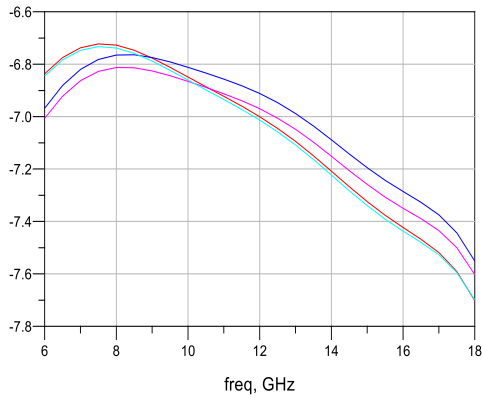

Isolation vs. Frequency

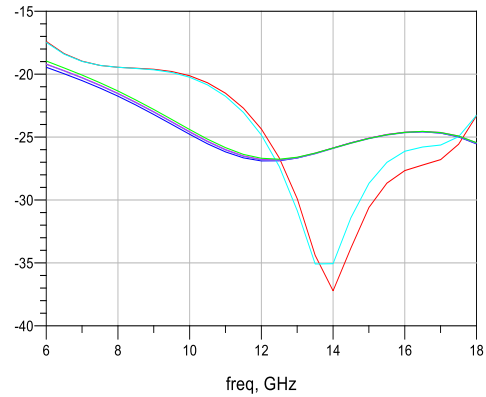

Return Loss vs. Frequency

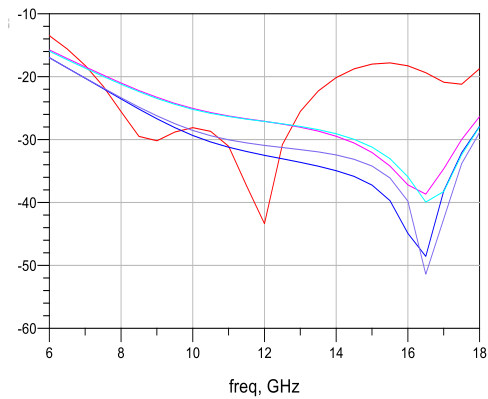



Outline Drawing: All Dimensions in μm

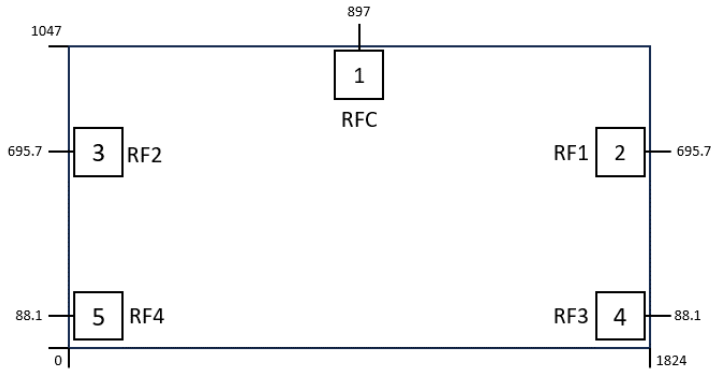

Assembly Drawing

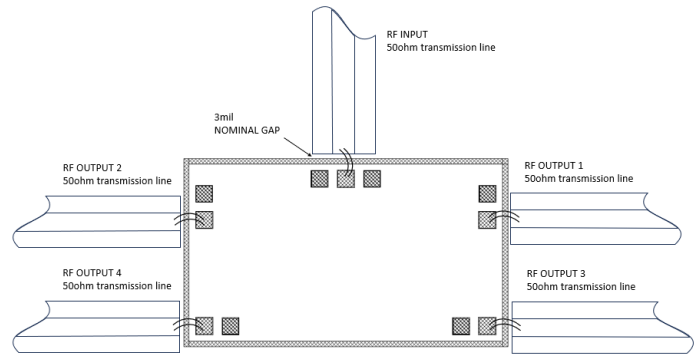

Absolute Maximum Ratings

RF Input Power	+40dBm
Operating Temperature	-55°C to +85 °C
Storage Temperature	-65°C to +150 °C

No	Symbol	Description
1	RF IN	RF Input Port
2,3,4,5	RF OUT	RF Output Port

Notes:

1. Die thickness: 100 μm
2. RF IN/OUT bond pad is 100 x 100 μm^2
3. Bond pad metalization: Gold
4. Backside metalization: Gold
5. Backside of the die (GND)

Miller MMIC Inc. All rights reserved

Miller MMIC, Inc. holds exclusive rights to the information presented in its Data Sheet and any accompanying materials. As a premier supplier of cutting-edge RF solutions, Miller MMIC has made this information easily accessible to its clients.

Although Miller MMIC believes the information provided in its Data Sheet to be trustworthy, the company does not offer any guarantees as to its accuracy. Therefore, Miller MMIC bears no responsibility for the use of this information. It is worth mentioning that the information within the Data Sheet may be altered without prior notification.

Customers are encouraged to obtain and verify the most recent and pertinent information before placing any orders for Miller MMIC products. The information in the Data Sheet does not confer, either explicitly or implicitly, any rights or licenses with regards to patents or other forms of intellectual property to any third party.

The information provided in the Data Sheet, or its utilization, does not bestow any patent rights, licenses, or other forms of intellectual property rights to any individual or entity, whether in regards to the information itself or anything described by such information. Furthermore, Miller MMIC products are not intended for use as critical components in applications where failure could result in severe injury or death, such as medical or life-saving equipment, or life-sustaining applications, or in any situation where failure could cause serious personal injury or death.